

# Clayware, Chimney & Roofing

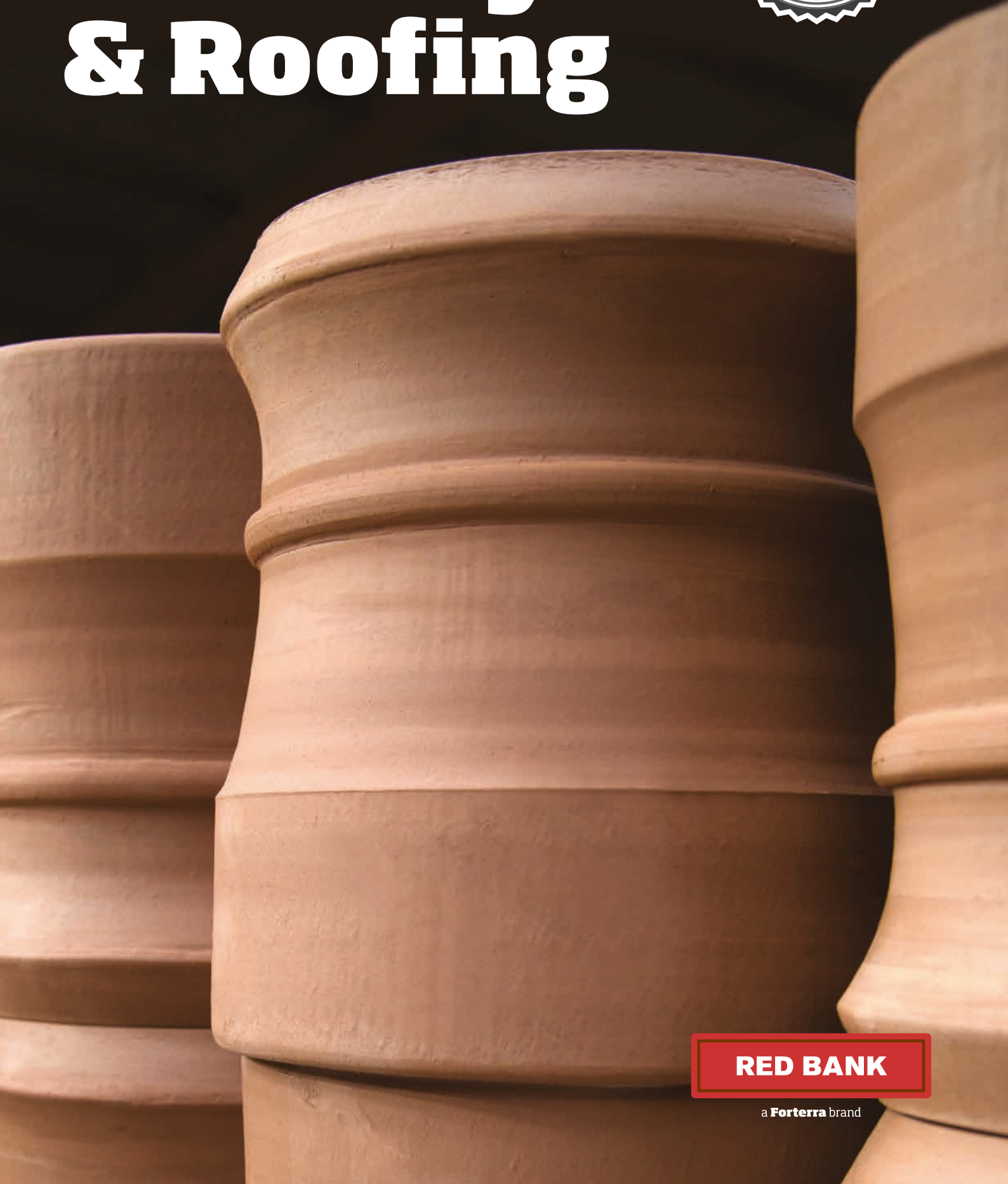

**RED BANK**

a Forterra brand

# Contents

Chimney Pots & Gas Flue Terminals		Clay Ridge Tiles & Finials	
Round Tapered	6	Plain & Capped Angle	30
Beaded Flue Terminals	7	Half Round	32
Octagons	9	Roll Top, Slotted Roll Top & Crested Ridge	33
Squares	11	Crested Stop Ends	36
Scottish	13	Scroll Finials	38
Louvres	14	Finials	40
Traditional	15	Finial Bases & Accessories	41
Ornamental	17	Dry Fix Ventilated Ridge & Hip System	43
'H'-Type	18	Suitability & Application Notes	46
Flue Terminals	19		
Inserts	21		
Gas Flue Terminals	23		
Decorative Fuel Effect Pots & Inserts	24		
Air Bricks & Cavity Wall Bridging Ducts	26		
Clay Class 1 Flue Liners	27		

## Easy guide to product selection by appliance type

We have developed an easy guide to ordering a suitable chimney pot for your chosen appliance. Our new colour coded icons below are shown against each product throughout the price list, making selection a quick and easy process.



**Solid Fuel Appliance**



**Gas Appliance**

Outlet size up to 125mm dia



**Open Decorative Fuel Effect Appliance**



**Gas Appliance**

Outlet size up to 150mm dia



**Solid Fuel Enclosed Appliance**



**Redundant Flue**

**Note:** Our product appliance guide is intended for guidance only, please consult with an approved appliance installer before making your purchase.

## Product colours

The Red Bank clayware product range is manufactured in three unique colours:



Red



Buff



Blue Black / Slate Bodymix\*

\* Slate Bodymix only available for Ridge Tiles & Finials

For individual product colour availability, pallet quantities and technical specification, visit [forterra.co.uk/redbank-selector](http://forterra.co.uk/redbank-selector)

All dimensions are in mm, drawings not to scale and all sizes nominal. The colours in this brochure are as true as can be obtained by the normal printing process. Red Bank is committed to a programme of continuous product development and reserve the right to alter specifications without prior notification. For further product information or assistance please telephone our sales team on 01530 273 737.

# Handmade heritage clayware for more than 100 years

**RED BANK**

Red Bank has been producing high quality chimney pots for over 100 years, and offer an unrivalled range of products that add distinction and character to any new build, restoration or renovation project.

We also offer a bespoke products service for the listed building and renovation sector. Our highly skilled and experienced craftsmen can produce bespoke ridge tiles, roof finials, chimney pots, copings, and many other products that are not available off-the-shelf.

**For more information call us on 01530 273 737**



List No. 127



List No. 7



List No. 58



Examples of our bespoke clayware chimney pots



# Round Tapered

## List No. 1

Roll Top

Height H	Base dia		Top dia	
	A	B	C	D
300, 375, 450, 600 750, 900	250	280	200	265

Made to order

1050, 1200, 1350	250	280	200	265
1500, 1800	265	300	220	300

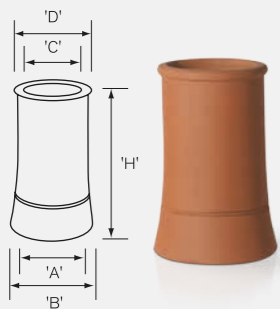

## List No. 4

Cannon Head - Traditional

Height H	Base dia		Top dia	
	A	B	C	D
300, 375, 450 600, 750, 900	250	280	200	280

Made to order

1050	250	280	200	280
1200, 1350, 1500 1650, 1800	265	300	225	320



## List No. 62

Roll Base

Height H	Base dia		Top dia	
	A	B	C	D
300, 375, 450, 600 750, 900	250	280	200	260

Made to order

1050	250	280	200	260
1200, 1350, 1500 1650, 1800	250	290	225	290

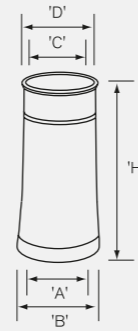

## List No. 150\*

Blanked Roll Top

Height H	Base dia		Top dia	
	A	B	C	D
300, 450, 600	250	285	-	275

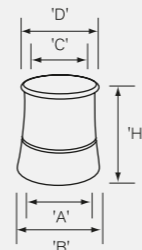

## List No. 114

Contemporary Cannon Head Pot

Height H	Base dia		Top dia	
	A	B	C	D
300, 375, 450 600, 750, 900	250	280	200	265

Made to order

1050	250	280	200	265
1200, 1350, 1500 1650, 1800	250	300	200	265

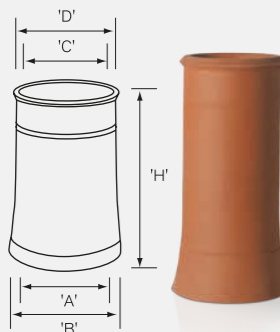

## List No. 151

Cannon Head Pot Blanked Top

Height H	Base dia		Top dia	
	A	B	C	D
300, 600	250	280	200	280

Made to order

1050	250	280	200	280
1200, 1350, 1500 1650, 1800	265	300	225	320

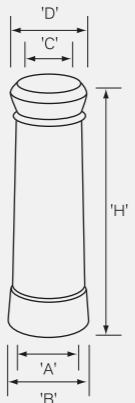

## List No. 175

BSS Type 4D to suit 200 int. sq. flues

Height H	Base dia		Top dia	
	A	B	C	D
300, 450	200 sq.	245 sq.	200 dia.	265 dia.

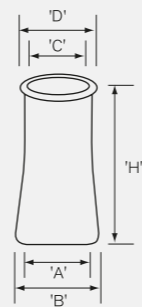

\*See notes on pages 46 and 47 regarding limited application. Note: Beaded Rebated Terminals to suit clay flue linings.

### Product colours



For further details on colour or pallet quantities visit [forterra.co.uk](http://forterra.co.uk)



# Beaded Flue Terminals

**List No. 175**  
BSS Type 4D to suit 250 int. sq. flues

Height H	Base dia		Top dia	
	A	B	C	D
300, 450	300 sq.	340 sq.	250 dia.	310 dia.

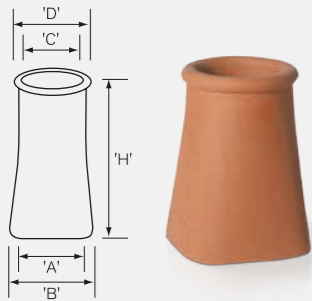

**List No. 175**  
BSS Type 4D to suit 300 int. sq. flues

Height H	Base dia		Top dia	
	A	B	C	D
300, 450	350 sq.	390 sq.	300 dia.	385 dia.

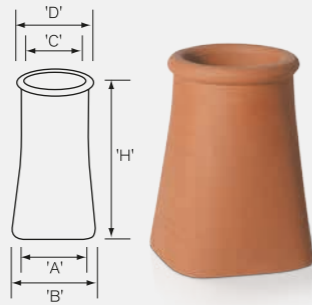

**List No. 180**  
BSS Type 6F to suit 225 dia flues

Height H	Base dia		Top dia	
	A	B	C	D
300, 450, 600 750, 900	225	270	225	285

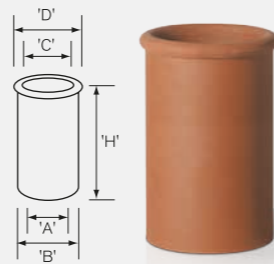

# Octagons

**List No. 36\***  
Octagon Louvre Pot

Height H	Base dia		Top dia	
	A	B	C	D
600, 750, 900	275	320	175	250

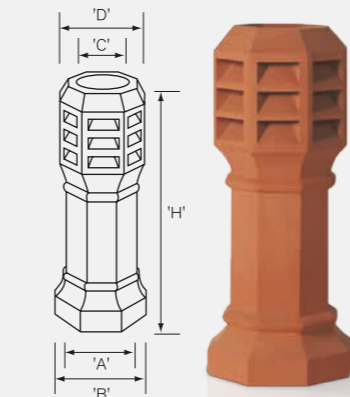

Suitable for certain solid fuel enclosed appliances only, please contact Red Bank for further information.



**List No. 39\***  
Plain Octagon Pot

Height H	Base dia		Top dia	
	A	B	C	D
600, 750, 900	265	315	150	290

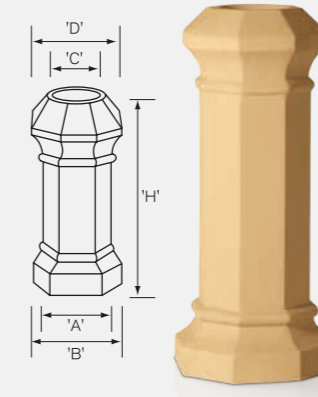

Suitable for certain solid fuel enclosed appliances only, please contact Red Bank for further information.



**List No. 53\***  
Square Base Octagon Pot (with hood)

Height H	Base sq		Top dia	
	A	B	C	D
375, 450	265	310	200	275

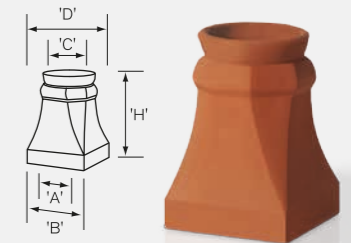

Not suitable for use with solid fuel when supplied with a hood - can only be used with redundant flues when supplied with hood.



**List No. 181**  
BSS Type 6F to suit 250 dia flues

Height H	Base dia		Top dia	
	A	B	C	D
300, 450, 600 750, 900, 1200	250	295	250	310

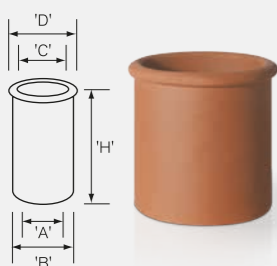

**List No. 182**  
BSS Type 6F to suit 300 dia flues

Height H	Base dia		Top dia	
	A	B	C	D
300, 450, 600 750, 900	300	360	300	385

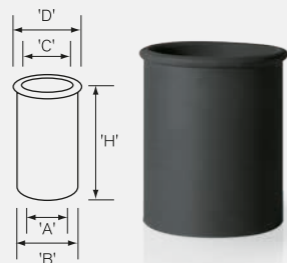

**List No. 183**  
BSS Type 6F to suit 350 dia flues

Height H	Base dia		Top dia	
	A	B	C	D
300, 450, 600 750, 900	350	360	350	385

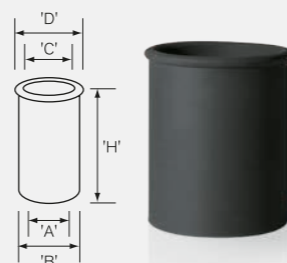

\*See notes on pages 46 and 47 regarding limited application. Note: Beaded Rebated terminals to suit clay flue linings.

**Product colours**  
 Red Buff Blue Black

For further details on colour or pallet quantities visit [forterra.co.uk](http://forterra.co.uk)



# Octagons

## List No. 79

Octagon Pot

Height H	Base dia		Top dia	
	A	B	C	D
525, 750	250	300	200	285

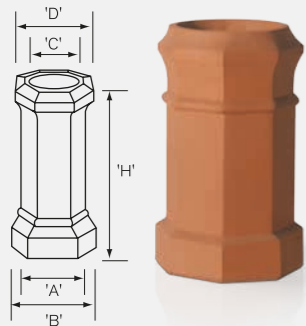

## List No. 80

Octagon Pot

Height H	Base dia		Top dia	
	A	B	C	D
600, 750, 900	290	340	240	350

Made to order  
1000, 1200, 1500, 1800 290 340 240 350

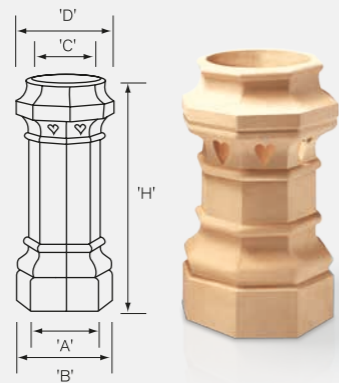

## List No. 81\*

Octagon Pot

Height H	Base dia		Top dia	
	A	B	C	D
600, 750, 900	250	300	180	300

Made to order  
750, 1050 365 425 300 415

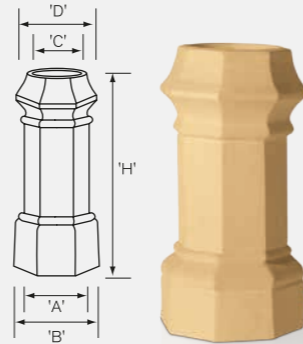

250mm internal diameter suitable for certain solid fuel enclosed appliances only, not suitable for solid fuel open fires - please contact Red Bank for further information.



# Squares

## List No. 7

Square Panelled Pot

Height H	Base sq		Top sq	
	A	B	C	D
Made to order 550	265	315	200	300

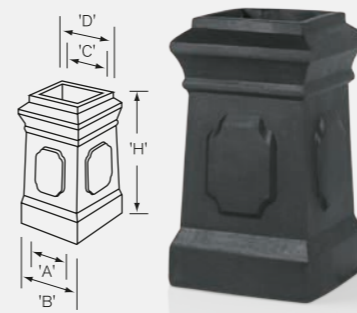

## List No. 16

Square Plain Pot

Height H	Base sq		Top sq	
	A	B	C	D
Made to order 450, 600, 750	265	315	200	300

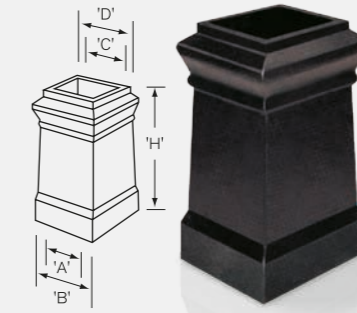

## List No. 27

Square Spiked Pot

Height H	Base sq		Top sq	
	A	B	C	D
Made to order 650, 750	250	300	200	285

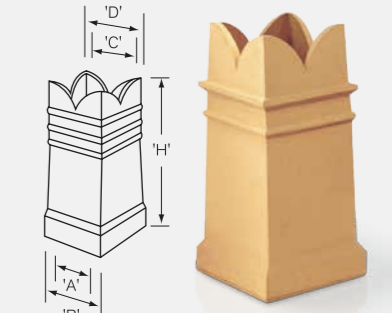

## List No. 126

Octagon Pot Square Base

Height H	Base sq		Top dia	
	A	B	C	D
450	265	310	200	275

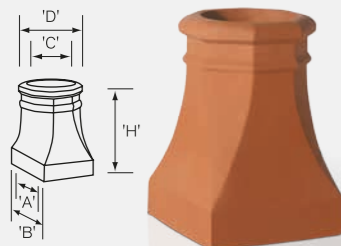

## List No. 66

Square Pot

Height H	Base sq		Top sq	
	A	B	C	D
Made to order 525	250	315	240	315

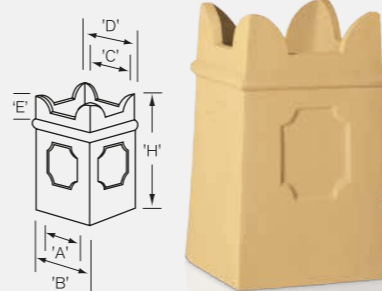

## List No. 67

Square Pot

Height H	Base sq		Top sq	
	A	B	C	D
Made to order 450	225	275	225	300

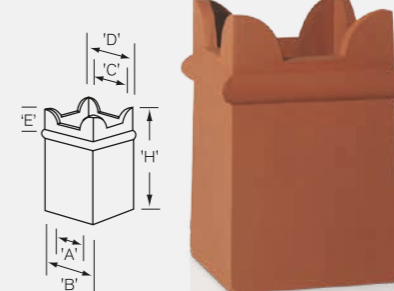

## List No. 69\*

Square Taper Pot

Height H	Base sq		Top sq	
	A	B	C	D
Made to order 300	240	290	160	200

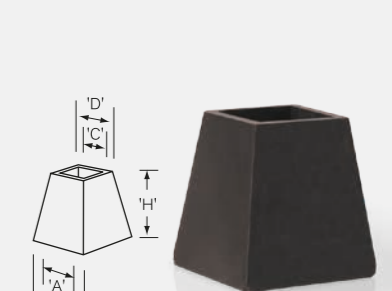

\*See notes on pages 46 and 47 regarding limited application.

\*See notes on pages 46 and 47 regarding limited application.

### Product colours

Red Buff Blue Black

For further details on colour or pallet quantities visit [forterra.co.uk](http://forterra.co.uk)



# Squares



**List No. 88**  
Hooded Square/with Pockets

Height H	Base sq				Top sq			
	A	B	C	D	E	F	G	J
875 (place to suit 250sq.)	250	315	210	430	90	225	140	360
875 (place to suit 330 sq.)	300	370	250	350	100	275	140	400

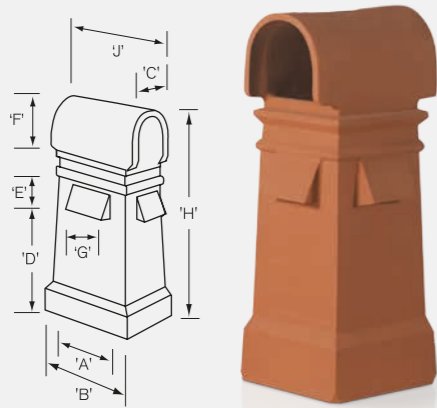

**Product colours**  
 Red
  Buff
  Blue Black

For further details on colour or pallet quantities visit [forterra.co.uk](http://forterra.co.uk)

# Scottish

**List No. 100**  
Plain Can

Height H	Base dia		Top dia	
	A	B	C	D
450, 600, 750, 900	250	290	215	265

**Made to order**  
1050, 1200      250 290 215 265

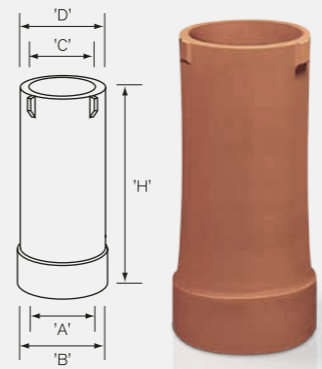

**List No. 101**  
Horned Can

Height H	Base dia		Top dia	
	A	B	C	D
450, 600, 750, 900	260	290	215	265

**Made to order**  
1050, 1200, 1500      260 290 215 265

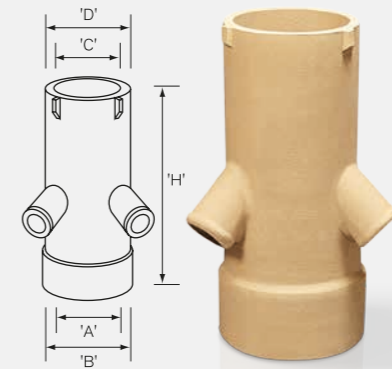

**List No. 102**  
Plain Cap 225mm Diameter

Height H	Base dia		Top dia	
	A	B	C	D
265	250	300	210	270

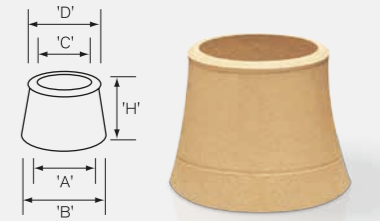

**List No. 104**  
Horned Cap 225mm Diameter

Height H	Base dia		Top dia	
	A	B	C	D
265	300	350	210	270

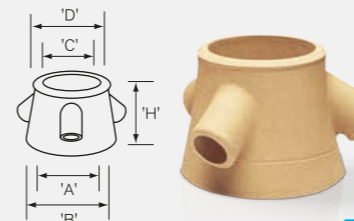

**List No. 115**  
3 Horned Roll Pot

Height H	Base dia		Top dia	
	A	B	C	D
450, 600, 750, 900	260	290	200	260

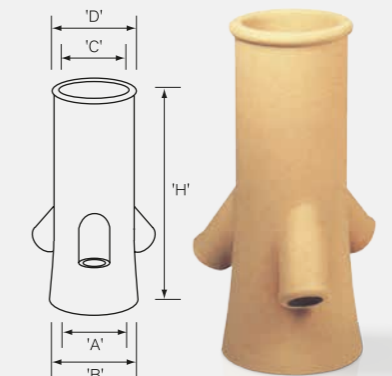

**List No. 628**  
Edinburgh Two Roll Can

Height H	Base dia		Top dia		
	A	B	C	D	E
600, 750, 900	225	260	225	275	180

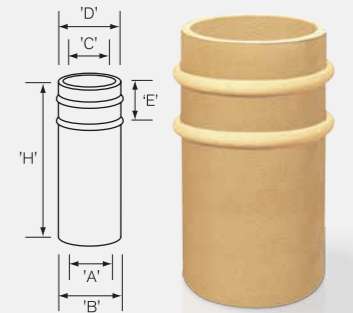

# Louvres

## List No. 11

Louvre

Height H	Base dia		Top dia			
	A	B	C	D	E	F
450 600, 750	240	290	200	295	75	90

Made to order

1200, 1350, 1500, 1650, 1800	250	300	200	295	75	90
------------------------------	-----	-----	-----	-----	----	----

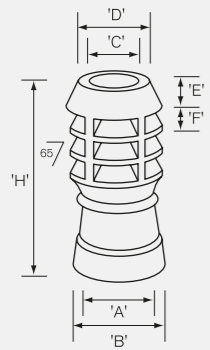

# Traditional

## List No. 6\*

Bishop

Height H	Base sq		Top dia		
	A	B	C	D	E
600, 750, 900	290	340	185	260	295

Made to order

1050	290	340	185	260	295
------	-----	-----	-----	-----	-----

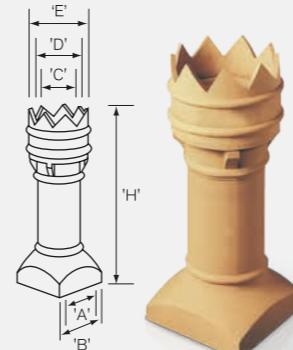

Suitable for certain solid fuel enclosed appliances only, please contact Red Bank for further information.



## List No. 31

Barrel Top

Height H	Base dia		Top dia		
	A	B	C	D	E
600, 750, 900	250	290	200	375	-

Made to order

1050	250	290	200	375	-
------	-----	-----	-----	-----	---



## List No. 58\*

Venetian

Height H	Base dia		Top dia		
	A	B	C	D	E
600, 750, 900	240	285	150	185	-

Made to order

1050	240	285	150	185	-
------	-----	-----	-----	-----	---

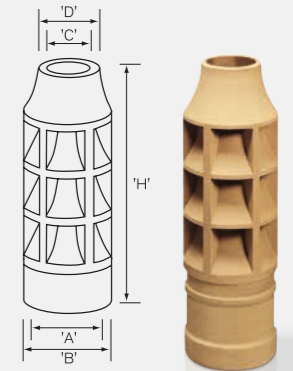

600mm high only has one louvre. Suitable for certain solid fuel enclosed appliances only, please contact Red Bank for further information.



## List No. 60\*

Marcone Plain Base

Height H	Base dia		Top dia		
	A	B	C	D	E
600, 990	200	240	175	220	325

Made to order

1220	200	240	175	220	325
------	-----	-----	-----	-----	-----

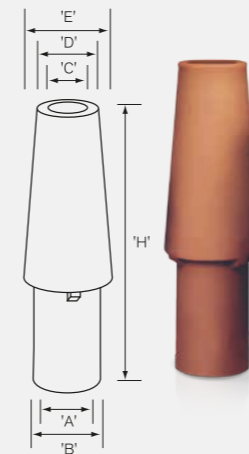

\*See notes on pages 46 and 47 regarding limited application.

### Product colours



For further details on colour or pallet quantities visit [forterra.co.uk](http://forterra.co.uk)





# Traditional

## List No. 59\*

Georgian

Height H	Base dia		Top dia			
	A	B	C	D	E	F
<b>Made to order</b>						
600	260	310	200	250	340	310

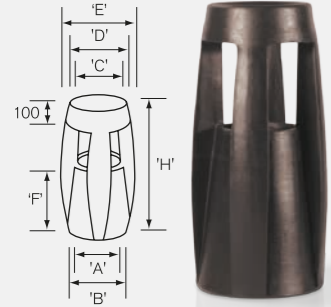

Suitable for certain solid fuel enclosed appliances only, please contact Red Bank for further information.



## List No. 60\*

Marcone Flanged Base

Height H	Base dia		Top dia			
	A	B	C	D	E	F
<b>Made to order</b>						
1220	240	275	175	220	325	-

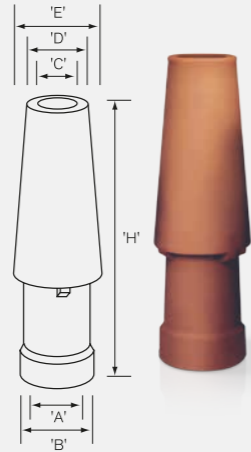

## List No. 127

Round Based

Height H	Base dia		Top dia			
	A	B	C	D	E	F
600, 750, 900, 1050	290	325	200	280	320	
600, 750, 900, 1050	305	345	225	320	360	
600, 750, 900, 1050	325	365	250	320	360	
600, 750, 900, 1050	380	420	300	375	415	

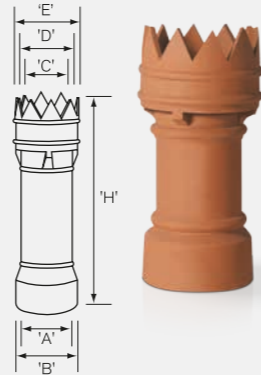

# Ornamental

## List No. 43

Roek

Height H	Base dia		Top dia			
	A	B	C	D	E	F
500	260	300	200	240	45	-
<b>Made to order</b>						
375	250	290	200	240	55	-

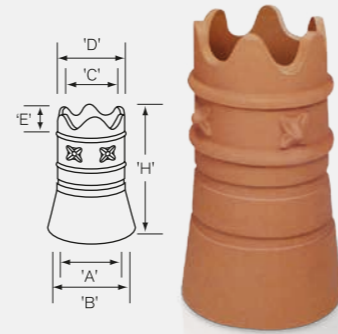

## List No. 52

Dublin Can

Height H	Base dia		Top dia		
	A	B	C	D	E
600, 750, 900	260	295	210	240	-

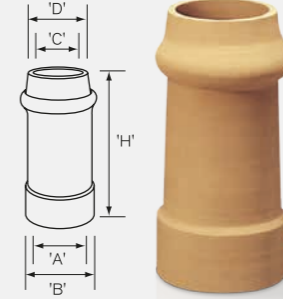

## List No. 91\*

Irish Roll

Height H	Base dia		Top dia	
	A	B	C	D
300, 375, 450 500, 550, 600	210	250	175	240

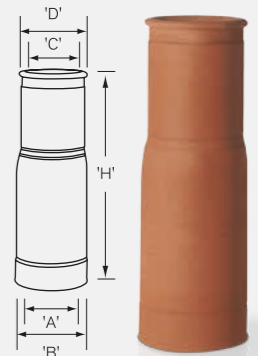

Suitable for certain solid fuel enclosed appliances only, please contact Red Bank for further information.



\*See notes on pages 46 and 47 regarding limited application.



\*See notes on pages 46 and 47 regarding limited application.

### Product colours



For further details on colour or pallet quantities visit [forterra.co.uk](http://forterra.co.uk)



# H-Type

**List No. 97**

'H' Pot

Height H	Base dia		Top dia			
	A	B	C	D	E	F
600, 750, 900	260	290	200	240	750	375

Made to order

1050, 1200	260	290	200	240	750	375
------------	-----	-----	-----	-----	-----	-----

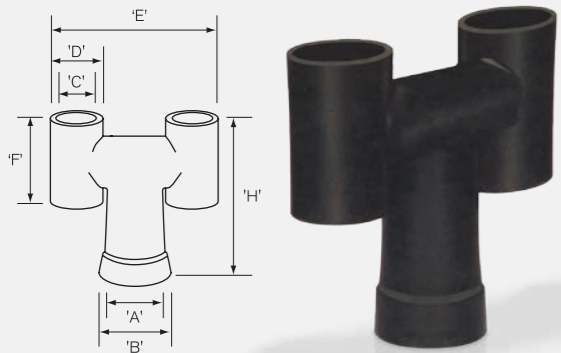

# Flue Terminals

to suit large Rectangular and Circular Flues

**List No. 130**

Beaded Flue Terminal

Height H	Base dia		Top dia	
	A	B	C	D
600	350	400	350	425

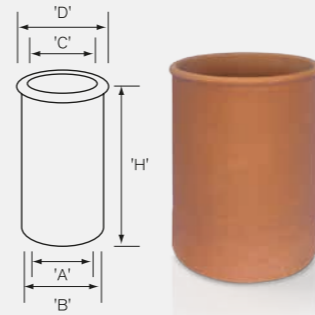

**List No. 131**

Beaded Flue Terminal

Height H	Base dia		Top dia	
	A	B	C	D
450, 600	400	450	400	475

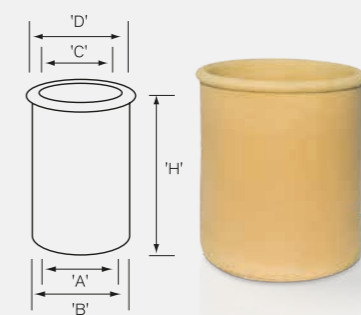

**List No. 160**

435 x 310mm Internal Rectangular Plain Beaded Flue Terminal

Height H	Base dia		Top dia	
	A	B	C	D
450, 600	450x320	480x380	450x320	520x400

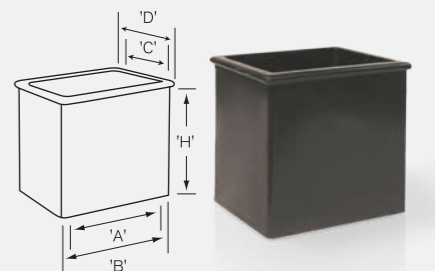

**List No. 161**

545 x 310mm Internal Rectangular Plain Beaded Flue Terminal

Height H	Base dia		Top dia	
	A	B	C	D
450, 600	565x320	630x380	565x320	650x400

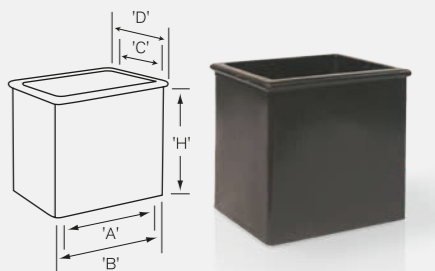

Product colours



For further details on colour or pallet quantities visit [forterra.co.uk](http://forterra.co.uk)



# Flue Terminals

to suit large Rectangular and Circular Flues

## List No. 162

435 x 310mm Internal Rectangular Fleur-de-Lys Flue Terminal

Height H	Base dia		Top dia	
	A	B	C	D
450,600	450x320	480x380	450x320	520x400

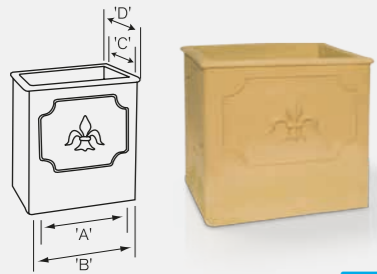

## List No. 163

545 x 310mm Internal Rectangular Fleur-de-Lys Flue Terminal

Height H	Base dia		Top dia	
	A	B	C	D
450,600	565x320	630x380	565x320	650x400

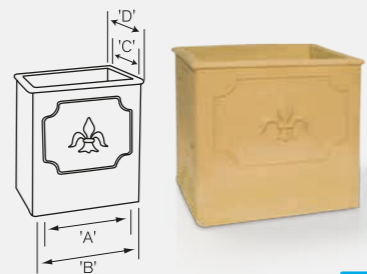

## List No. 164

435 x 310mm Internal Rectangular Castellated Flue Terminal

Height H	Base dia		Top dia	
	A	B	C	D
450,600	450x320	480x380	450x320	520x400

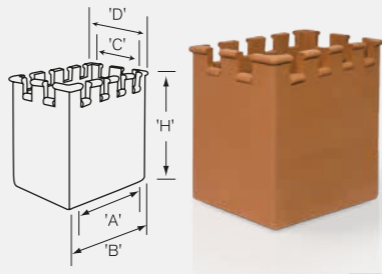

## List No. 165

545 x 310mm Internal Rectangular Castellated Flue Terminal

Height H	Base dia		Top dia	
	A	B	C	D
450,600	565x320	630x380	565x320	650x400

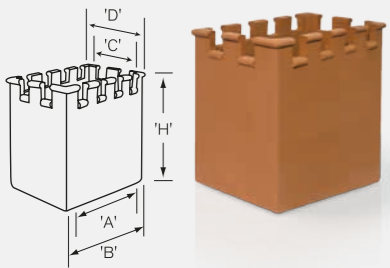

## List No. 166

Weatherguard Canopy - 635 x 510mm S/S to suit 435 x 310mm flues

Height H
600

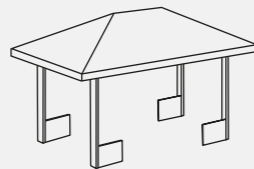

## List No. 167

Weatherguard Canopy - 745 x 510mm S/S to suit 545 x 310mm flues

Height H
600

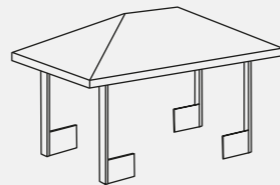

# Inserts

## List No. 30\*

Hood Top

Spigot ext. dia A	Spigot Height B	Overall Height C	Hood Width D	Spigot int. dia E
135	50	250	200	100
170	50	250	200	125
190	50	250	200	145
205	50	250	200	170
235	50	250	250	200

Made to Order

290

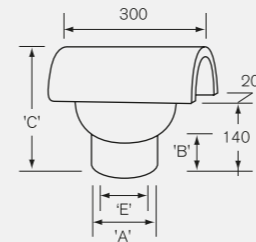

## List No. 103\*

Hood Top (Square Spigot)

Spigot ext. dia A	Spigot Height B	Overall Height C	Hood Width D
175	50	250	300

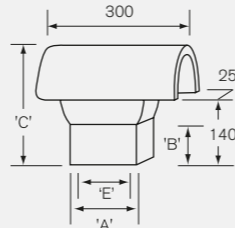

## List No. 116\*

Weatherguard Top

Spigot ext. dia A	Spigot Height B	Overall Height C	Hood Width D
135, 170	85	170	235
190, 205	85	170	285

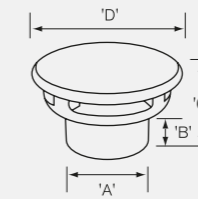

## List No. 117\*

Blank Stopper

Spigot ext. dia A	Spigot Height B	Overall Height C	Hood Width D
135	40	75	185
170, 190, 205	70	125	250

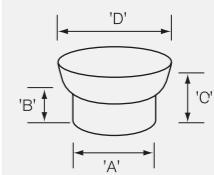

\*See notes on pages 46 and 47 regarding limited application.

### Product colours



For further details on colour or pallet quantities visit [forterra.co.uk](http://forterra.co.uk)



# Inserts

## List No. 118\* Mushroom Top Inside Fitting

Spigot ext. dia A	Spigot Height B	Overall Height C	Hood Width D
190	100	280	300
205	100	300	300

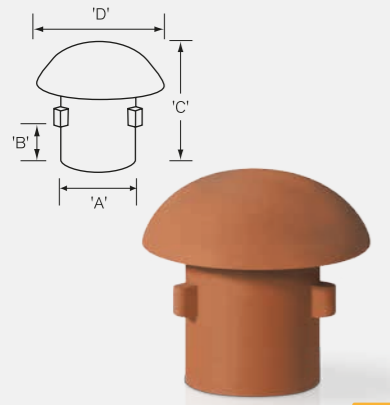

## List No. 119\* Mushroom Top Outside Fitting

Spigot ext. dia A	Spigot Height B	Overall Height C	Hood Width D
300	65	290	350

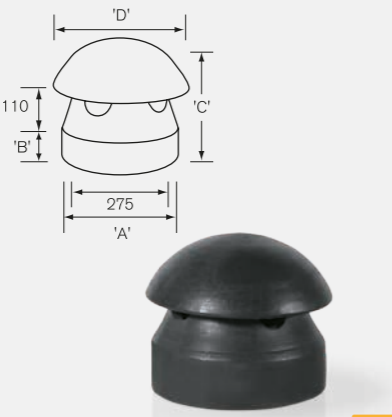

## List No. 120\* Flue Ventilator

Spigot ext. dia A	Spigot Height B	Overall Height C	Hood Width D
135, 190, 205	55	175	275
170	55	175	250
235	70	175	325

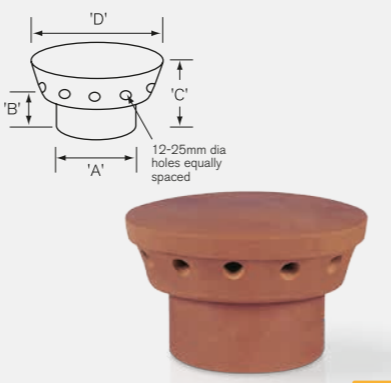

# Gas Flue Terminals

## List No. 613\* GC3 Insert

Height H	Spigot ext. dia A	Spigot int. dia B	Min. int. pot/flue dim. C	Top C
440	190	150	200	300
440	205	150	225	300

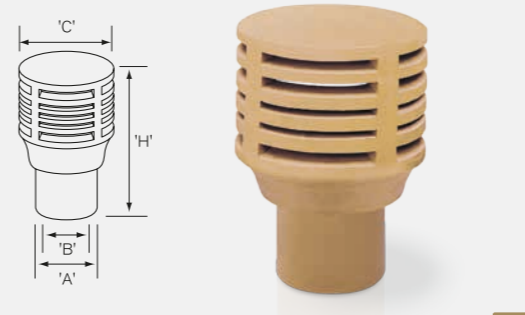

## List No. 625\* GC5 Insert

Height H	Spigot ext. dia A	Spigot int. dia B	Min. int. pot/flue dim. C	Top C	Spigot Height E
300	170	125	185	260	140
300	190	140	200	260	140
300	205	170	225	260	140

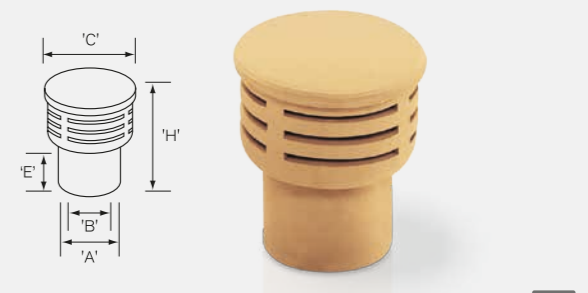

## List No. 636\* Clay Can and Fixing Plate

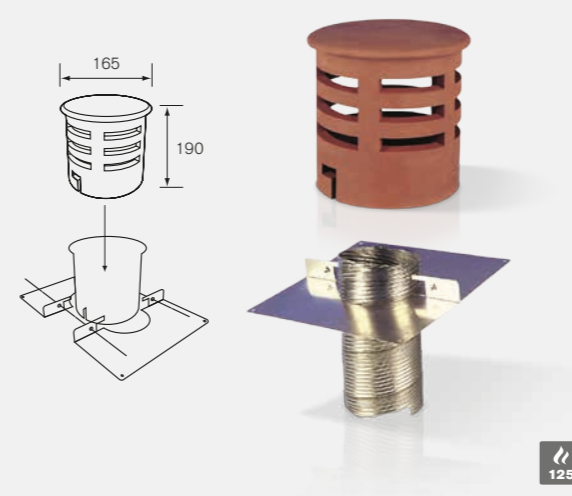

\*See notes on pages 46 and 47 regarding limited application.

\*See notes on pages 46 and 47 regarding limited application.

**Product colours**  
 Red 
  Buff 
  Blue Black

For further details on colour or pallet quantities visit [forterra.co.uk](http://forterra.co.uk)



# Decorative

## Fuel Effect Pots and Inserts

### List No. 145\* DFE Pot

Height	Base Spigot ext.	Base Spigot int.	Hood	Skirt
H	A	B	C	D
560	285 dia	250 dia	300	-

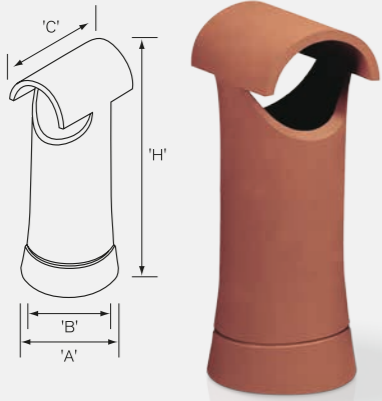

For use with decorative fuel effect gas appliances, refer to BS 5871 Part 3 2005 for installation guidance.



### List No. 146\* DFE Insert (Circular)

Height	Base/ Spigot ext.	Base/ Spigot int.	Hood	Skirt
H	A	B	C	D
435	215 dia	185 dia	300	280
450	235 dia	190 dia	300	280

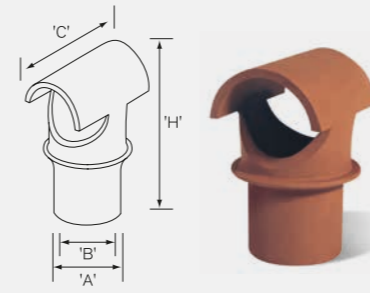

These inserts cannot be used with flue terminals less than 225mm int. dia. or 225mm int. square. Suitable for certain solid fuel enclosed appliances only, please contact Red Bank for further information.



### List No. 146\* DFE Insert (Square)

Height	Base/ Spigot ext.	Base/ Spigot int.	Hood	Skirt
H	A	B	C	D
450	210 sq	175 sq	300	300
500	235 sq	190 sq	300	315
510	270 sq	225 sq	380	380

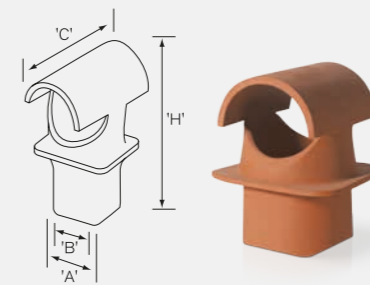

These inserts cannot be used with flue terminals less than 225mm int. dia. or 225mm int. square. Suitable for certain solid fuel enclosed appliances only, please contact Red Bank for further information.



### List No. 148\* DFE Insert with Birdguard (Circular)

Height	Base/ Spigot ext.	Base/ Spigot int.	Hood	Skirt
H	A	B	C	D
500	215 dia	185 dia	400	280
510	235 dia	190 dia	440	350
575	270 dia	225 dia	475	350

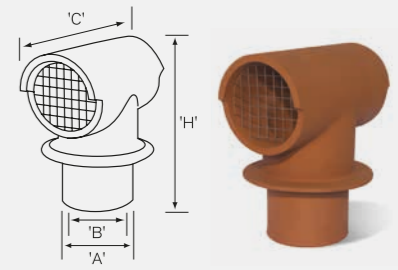

215 to suit 225, 235 to suit 250 and 270 to suit 300. These inserts cannot be used with flue terminals less than 225mm int. dia. or 225mm int. square. Suitable for certain solid fuel enclosed appliances only, and for open decorative fuel fires depending on existing pot size, please contact Red Bank for further information.



### List No. 147\* DFE Pot with Birdguard

Height	Base Spigot ext.	Base Spigot int.	Hood	Skirt
H	A	B	C	D
600	285 dia	250 dia	400	-

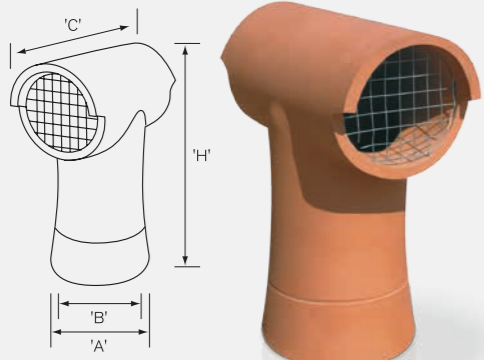

With stainless steel birdguard, for use with decorative fuel effect gas fires.



### List No. 148\* DFE Insert with Birdguard (Square)

Height	Base/ Spigot ext.	Base/ Spigot int.	Hood	Skirt
H	A	B	C	D
525	210 sq	175 sq	300	300
550	235 sq	190 sq	300	315
600	270 sq	225 sq	380	380

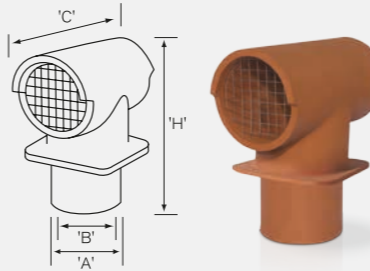

These inserts cannot be used with flue terminals less than 225mm int. dia. or 225mm int. square. Certain solid fuel enclosed appliances only - please contact Red Bank for further information. Suitable for open decorative fuel fires depending on existing pot size.



### List No. 149\* DFE Pot Circular Base with Birdguard

Height	Base/ Spigot ext.	Base/ Spigot int.	Hood	Skirt
H	A	B	C	D
600	410 dia	370 dia	600	-

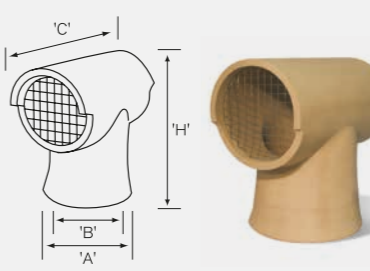

Certain solid fuel enclosed appliances only - please contact Red Bank for further information. Suitable for open decorative fuel fires depending on existing pot size.



### List No. 149\* DFE Pot Square Base with Birdguard

Height	Base/ Spigot ext.	Base/ Spigot int.	Hood	Skirt
H	A	B	C	D
600	395 sq	350 sq	600	-

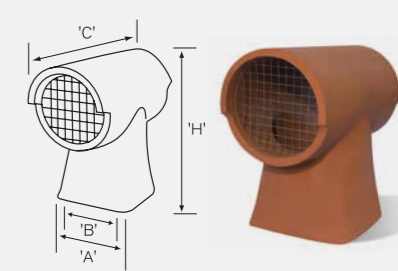

Certain solid fuel enclosed appliances only - please contact Red Bank for further information. Suitable for open decorative fuel fires depending on existing pot size.



\*See notes on pages 46 and 47 regarding limited application.

\*See notes on pages 46 and 47 regarding limited application.

#### Product colours

Red Buff Blue Black

For further details on colour or pallet quantities visit [forterra.co.uk](http://forterra.co.uk)



# Air Bricks & Cavity Wall Bridging Ducts

## List No. 350/351/352 Square Hole

List No.	Length A	Width B	Height C	Free air space (mm <sup>2</sup> ) (kg)
350	215	50	65	1300
351	215	50	140	2900
352	215	50	215	4500

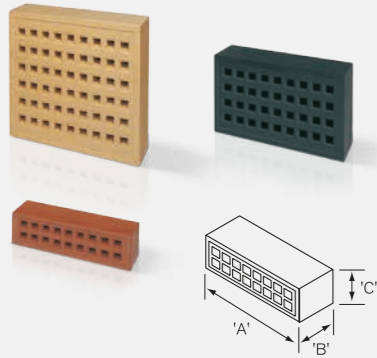

## List No. 363/364/365 Louvre

List No.	Length A	Width B	Height C	Free air space (mm <sup>2</sup> ) (kg)
363	215	50	65	1400
364	215	50	140	2800
365	215	50	215	4500

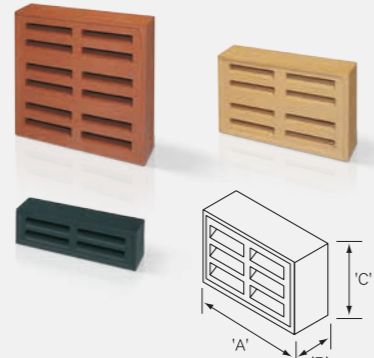

## List No. 372/373/374 Rectangular Hole Slotted

List No.	Length A	Width B	Height C	Free air space (mm <sup>2</sup> ) (kg)
372	215	50	65	2300
373	215	50	140	6000
374	215	50	215	10250

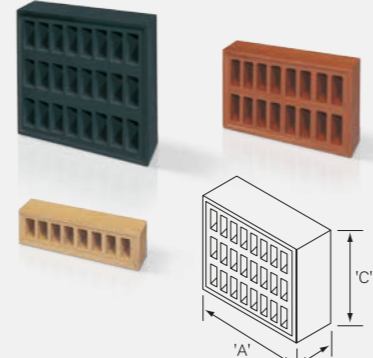

## List No. 400 Horizontal CWBD 200 - Red

Length A	Width B	Height C	Weight (kg)
200	215	65	4.1



## List No. 401 Horizontal CWBD 200 - Red

Length A	Width B	Height C	Weight (kg)
200	215	140	5.8

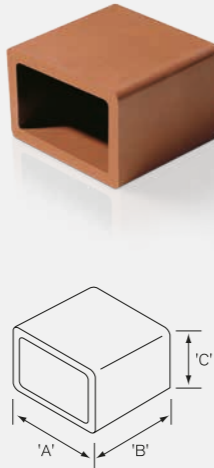

## List No. 402 Horizontal CWBD 200 - Red

Length A	Width B	Height C	Weight (kg)
200	215	215	8.2

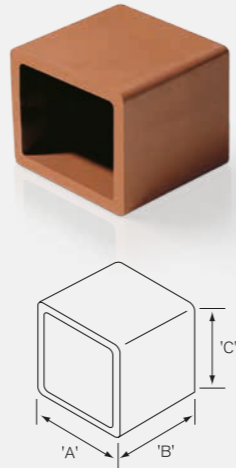

# Clay Class 1 Flue Liners

## List No. 494 Clay Type A1 Flue Liner to suit 225mm dia.

Height H	Base dia		Top dia	
	A	B	C	D
180	225	275	225	275
300	225	275	225	275
450	225	275	225	275
600	225	275	225	275

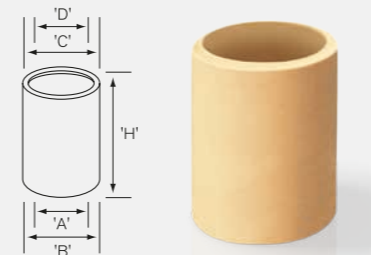

## List No. 495 Clay Type A1 Flue Bend

Offset angle	Base dia	
	A	B
22.5°, 30°, 37.5°	225	275



Please refer to our Rediflow Product Range and Price Guide for our larger range of concrete flues.

## List No. 740 Refractory Concrete Fyrite Throat Unit

Length A	Width B	Height C	Weight (kg)
720	375	280	53.65

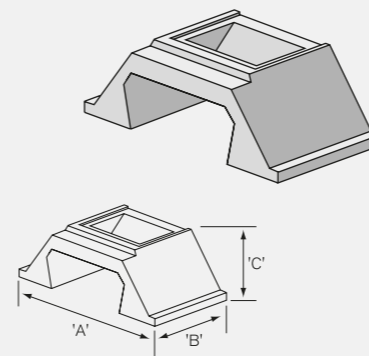

## List No. 744 Front Brick

Weight (kg)
53.65

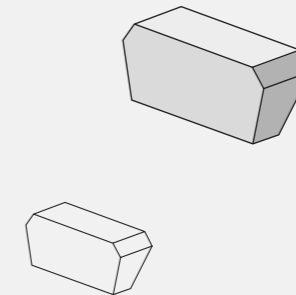

## List No. 743 Circular Flue Starter 225mm int. dia.

Height C	Weight (kg)
140	53.65

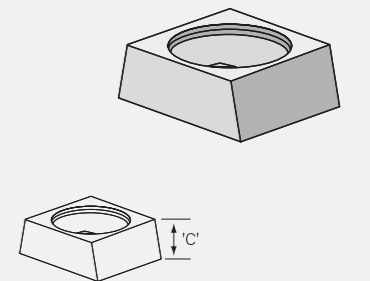

**Product colours**  
 Red
  Buff
  Blue Black

For further details on colour or pallet quantities visit [forterra.co.uk](http://forterra.co.uk)





# Clay Ridge Tiles & Finials

Red Bank manufacture ridge tiles and finials for all types of building projects. The flexibility of Red Bank's manufacturing process ensures that the most unusual or one off designs can be matched. Skilled craftsmen can also reproduce the most intricate patterns, satisfying the demands of conservationists.

Continuous investment ensures that products can be supplied from Red Bank to all parts of the country, with the minimum of delay.



### Standard Ridge Roof Angles

Roof Angles are usually given by their pitch (the angle at the eaves). The main ridge angle is the internal angle at the apex ( $180^\circ$  minus twice roof pitch).

As a guide the table below gives the most suitable standard ridge angle for use on hips.

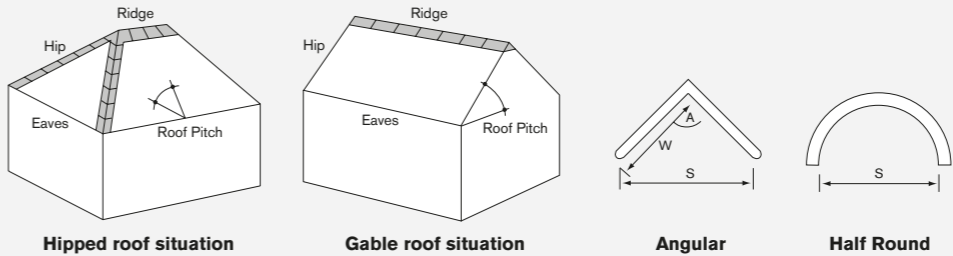

Main Apex	Hip	Angle	Span	Wing Length	Half Round Span
		A	S	W	S
75°	105°	75°	185	150	75
90°	115°	90°	215	150	100
105°	125°	105°	240	150	150
115°	135°	115°	260	150	200
125°	135°	125°	275	150	225
135°	135°	135°	310	175	250

# Plain & Capped Angle

**List No. 264**

Plain Angle Ridge

Length	Angle
A	B
450	75, 90, 105, 115, 125, 135

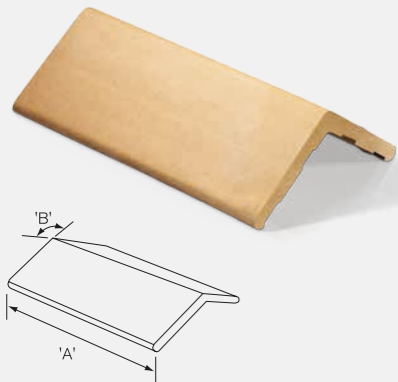

**List No. 265**

Plain Angle Hip Stop End

Length	Angle
A	B
450	75, 90, 105, 115, 125, 135

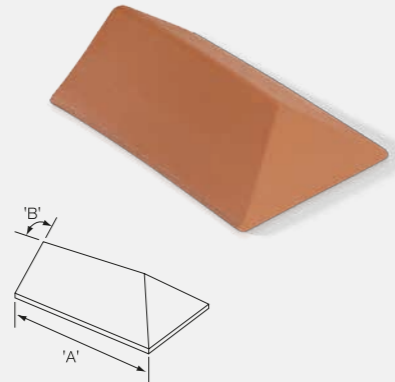

**List No. 268**

Plain Angle Quoin End

Length	Angle
A	B
450	90, 105, 115, 125, 135

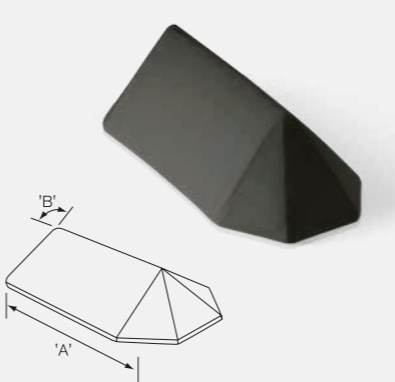

**List No. 302**

Plain Angle Gable Stop End

Length	Angle
A	B
450	90, 105, 115, 125, 135

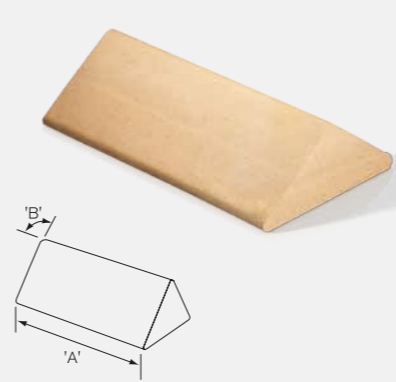

**List No. 285**

Capped Angle Ridge (One nail hole)

Length	Angle
A	B
450	75, 90, 105, 115, 125, 135

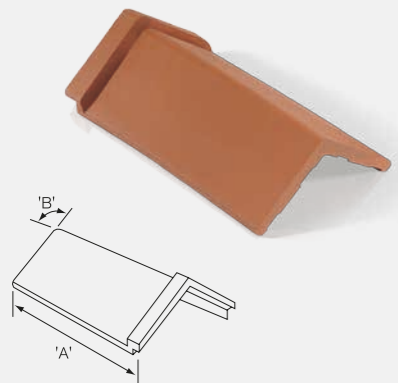

**List No. 296**

Capped Angle Hip Stop End

Length	Angle
A	B
Made to order	
450	75, 90, 105, 115, 125, 135

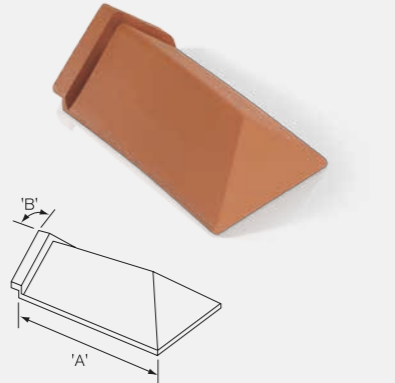

**List No. 267**

Capped Angle Pen Point

Length	Angle
A	B
450	75, 90, 105, 115, 125, 135



**List No. 304**

Capped Angle Gable Stop End

Length	Angle
A	B
Made to order	
300, 450	75, 90, 105, 115, 125, 135

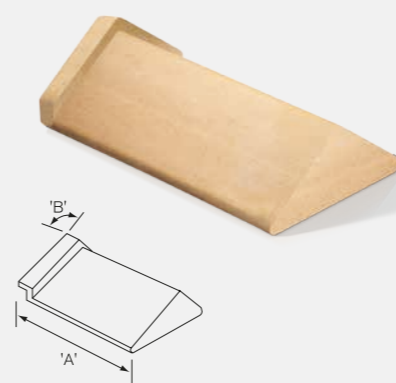

**Product colours**



For further details on colour or pallet quantities visit [forterra.co.uk](http://forterra.co.uk)



# Half Round

**List No. 258**  
Plain Half Round Ridge

Length A	Span B
300, 450	225

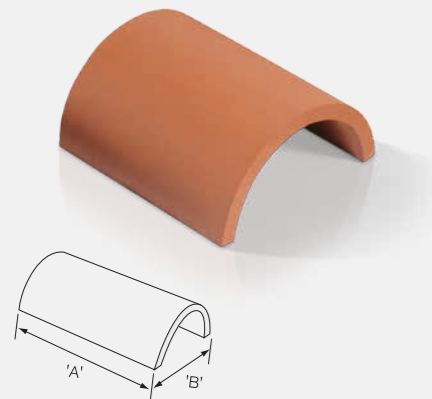

**List No. 260G**  
Plain Half Round Gable Stop End

Length A	Span B
<b>Made to order</b>	
300, 450	225

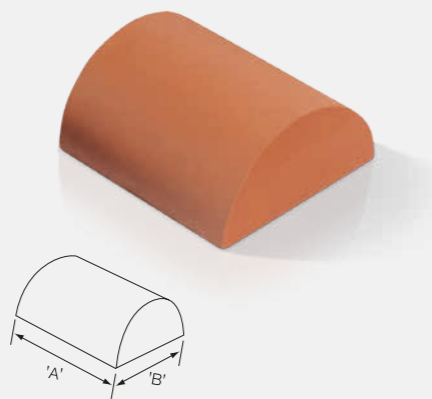

**List No. 260H**  
Plain Half Round Hip Stop End

Length A	Span B
<b>Made to order</b>	
300, 450	225

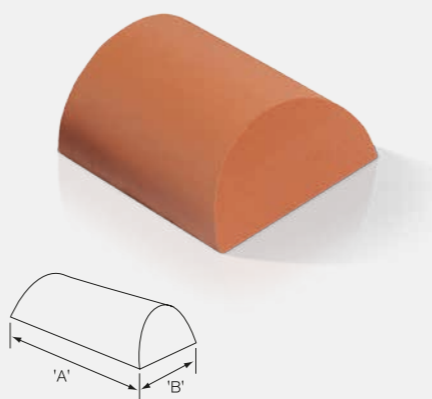

# Roll Top, Slotted Roll Top & Crested Ridge

**List No. 270H**  
Roll Top Hip Stop End

Length A	Angle B
<b>Made to order</b>	
300, 450	75, 90, 105, 115, 125, 135

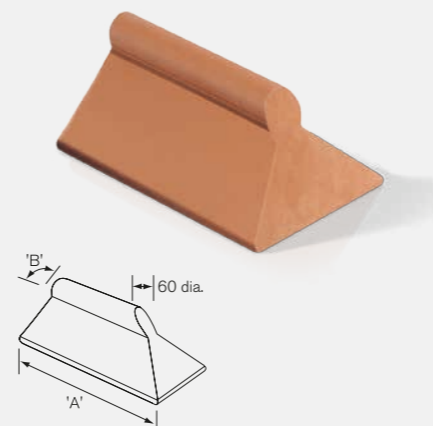

**List No. 284**  
Roll Top Ridge

Length A	Angle B
450	75, 90, 105, 115, 125, 135

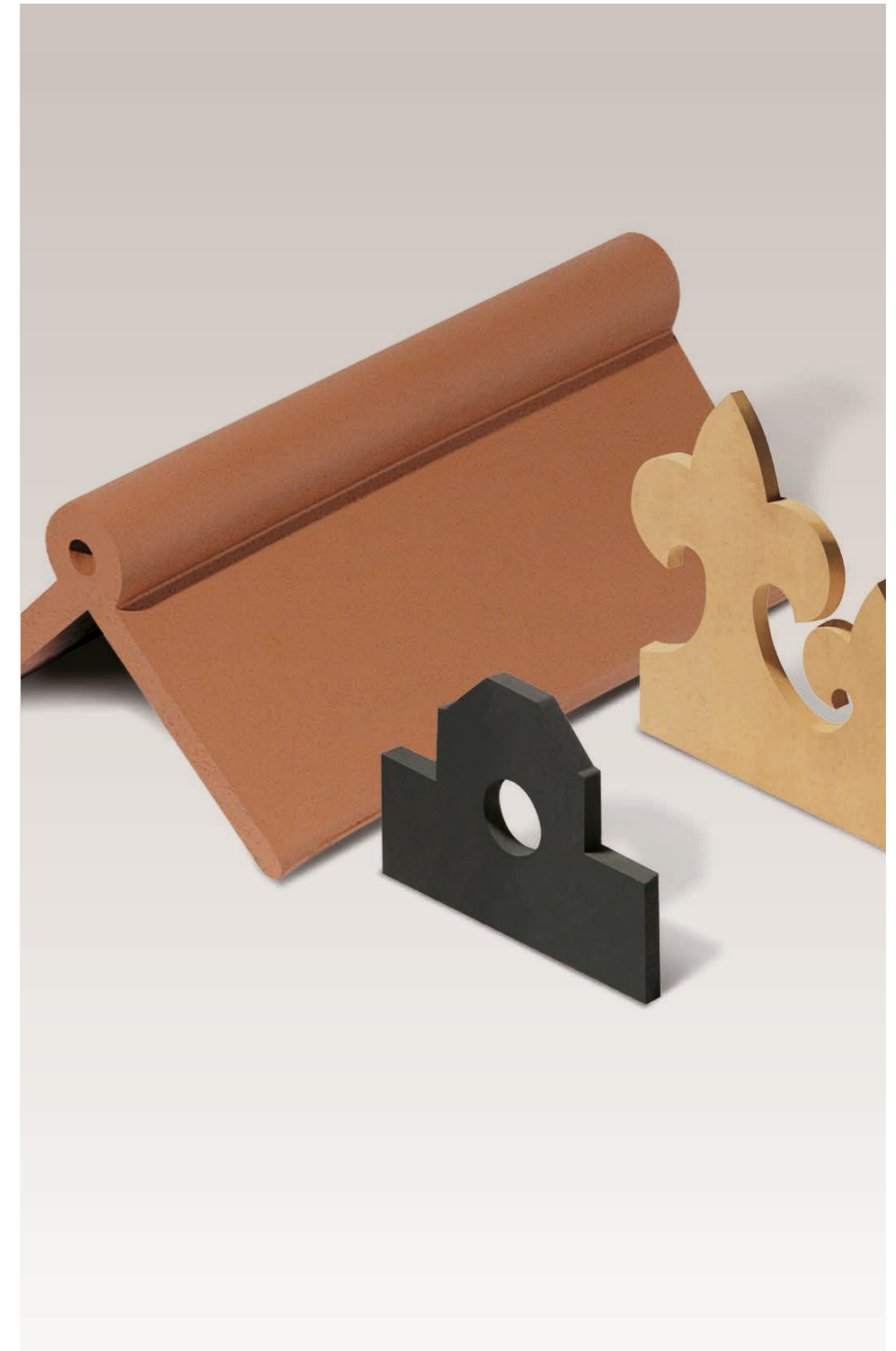

# Roll Top, Slotted Roll Top & Crested Ridge

**List No. 311**  
Slotted Roll Top Ridge

Length A	Angle B
450	75, 90, 105, 115, 125, 135

Standard Slot Roll Top Insert Pattern.  
Other angle sizes available to order.

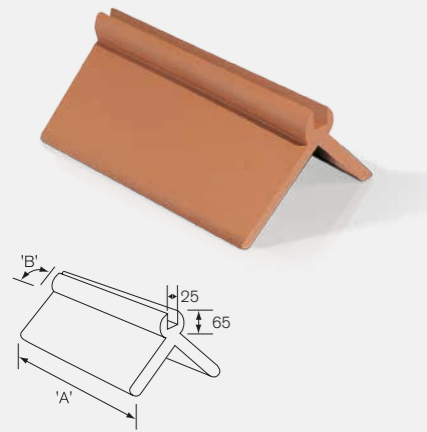

**List No. 286**  
Plain Crested Ridge

Length A	Angle B	Height of Crest C
300	75, 90, 105, 115, 125, 135	25, 40, 50, 75, 100, 125, 150 (Applicable to all angles)

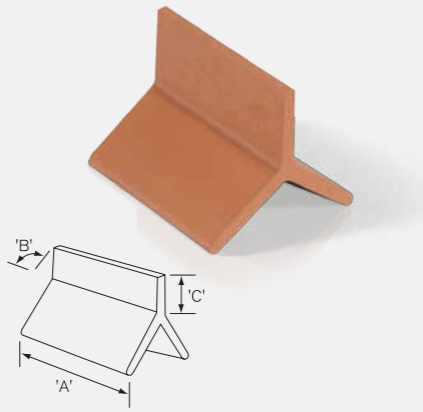

**List No. 287**  
Two Hole Crested Ridge

Length A	Angle B	Height of Crest C
300	75, 90, 105, 115, 125, 135	125

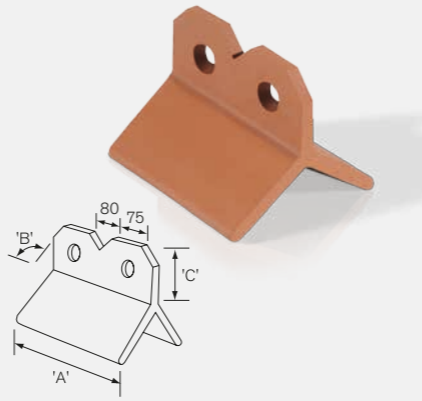

**List No. 288**  
Club Crested Ridge

Length A	Angle B	Height of Crest C
300	75, 90, 105, 115, 125, 135	125

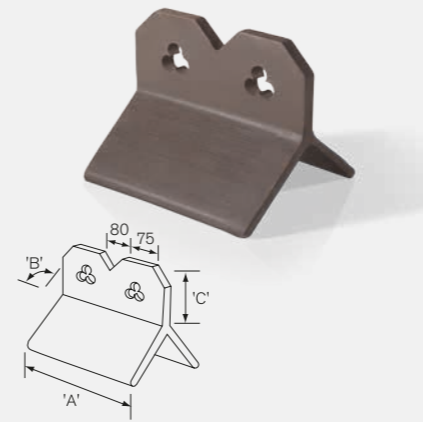

**List No. 312**  
Fleur-de-Lys Single Insert

Length A	Height B
150	210

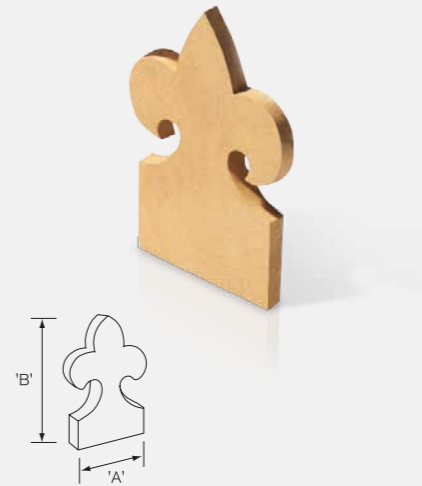

**List No. 313**  
Fleur-de-Lys Double Insert

Length A	Height B
225	220

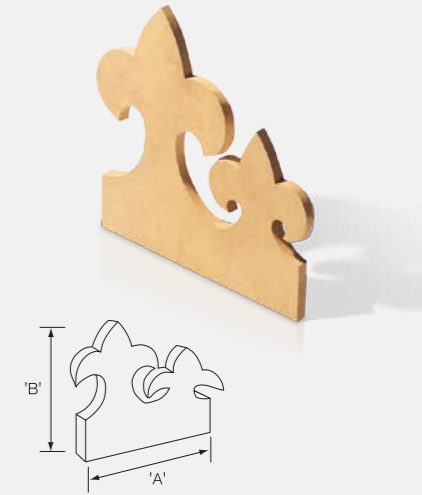

**List No. 289**  
Cocks Comb Crested Ridge

Length A	Angle B	Height of Crest C
300	75, 90, 105, 115, 125, 135	75

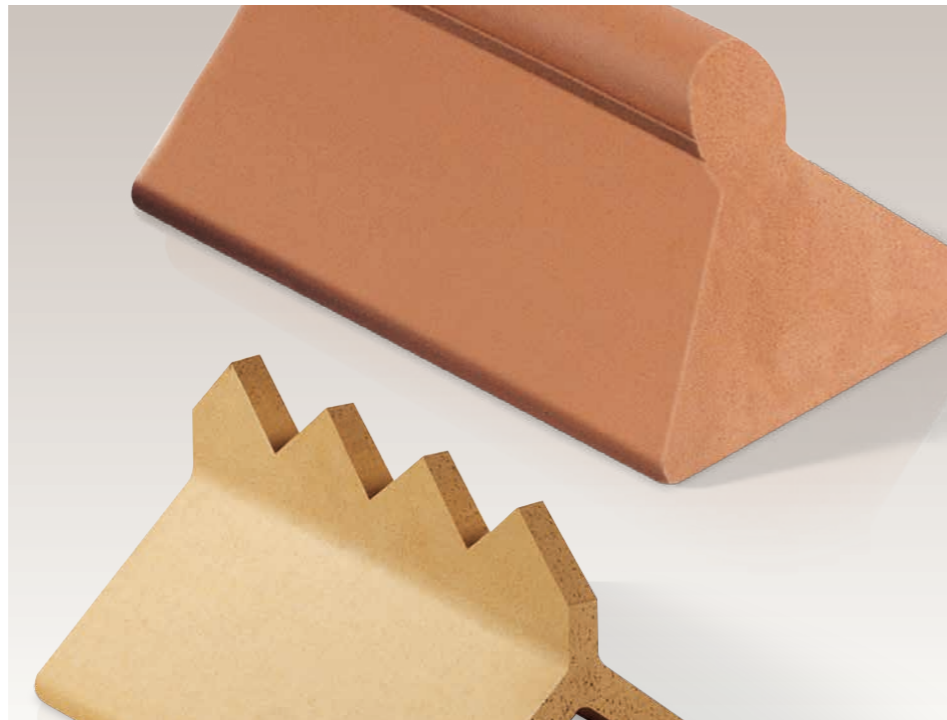
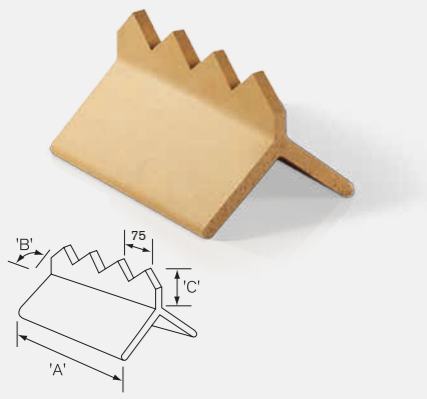

**List No. 314**  
Cross Pattern Insert

Length A	Height B
Made to order	
140	190



**List No. 321**  
One Hole Insert

Length A	Height B
200	150

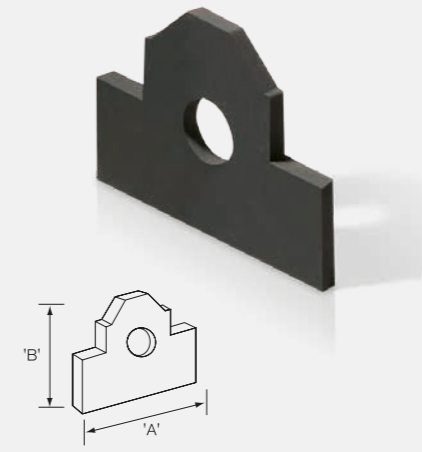

**Product colours**  
 Red 
  Buff 
  Slate Bodymix

For further details on colour or pallet quantities visit [forterra.co.uk](http://forterra.co.uk)

# Crested Stop Ends

**List No. 277G**  
Plain Crested Gable Stop End

Angle	Crest Height C	Length A B
-------	-------------------	---------------

Made to order

75, 90, 105	25, 50, 75	300 300
115, 125, 135	100, 125, 150	

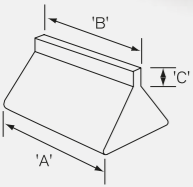

**List No. 277H**  
Plain Crested Hip Stop End

Angle	Crest Height C	Length A B
-------	-------------------	---------------

Made to order

45, 75, 90, 105	25, 50, 75	* 150
115, 125, 135	100, 125, 150	

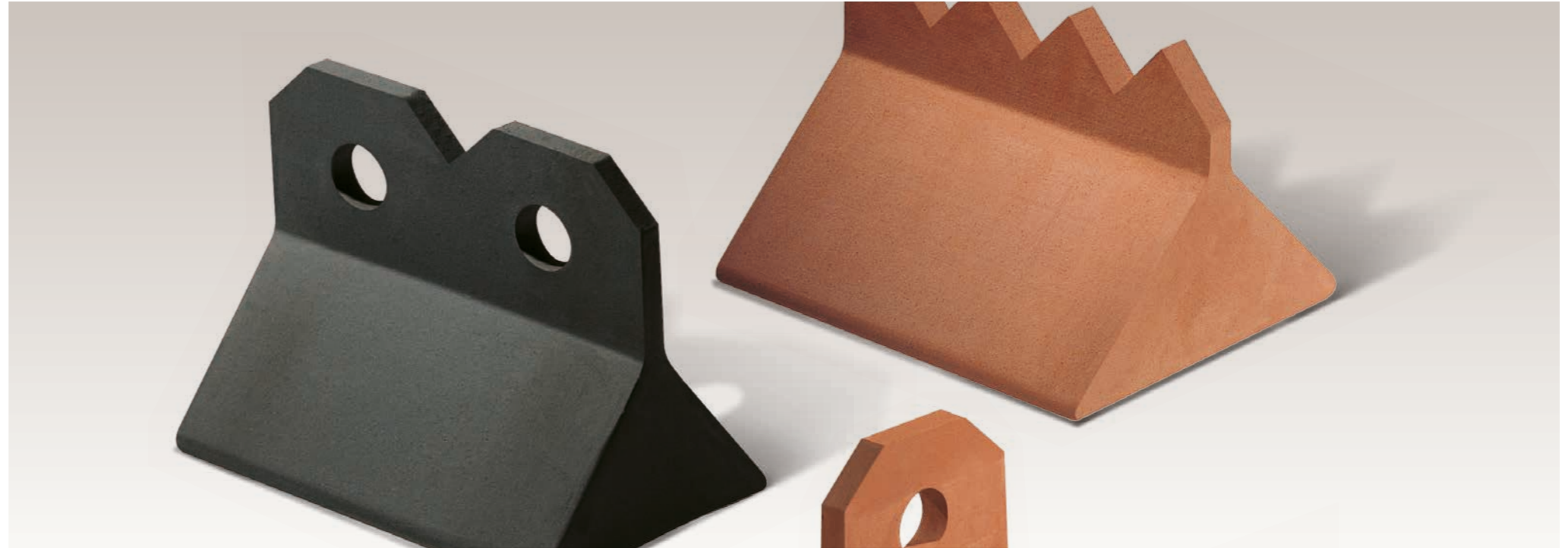
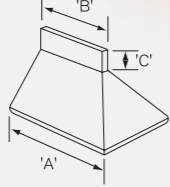

**List No. 287H**  
Two Hole Crested Hip Stop End

Angle	Crest Height C	Length A B
-------	-------------------	---------------

Made to order

75, 90, 105	125	* 150
115, 125, 135		

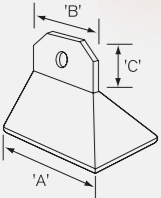

**List No. 288G**  
Club Crested Gable Stop End

Angle	Crest Height C	Length A B
-------	-------------------	---------------

Made to order

75, 90, 105	125	* 300
115, 125, 135		

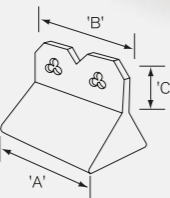

**List No. 288H**  
Club Crested Hip Stop End

Angle	Crest Height C	Length A B
-------	-------------------	---------------

Made to order

75, 90, 105	125	* 150
115, 125, 135		

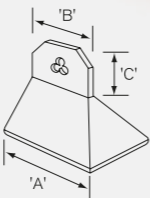

**List No. 289H**  
Cocks Comb Crested Hip Stop End

Angle	Crest Height C	Length A B
-------	-------------------	---------------

Made to order

70, 90, 105	75	* 150
115, 125, 135		

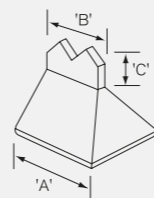

**List No. 289G**  
Cocks Comb Crested Gable Stop End

Angle	Crest Height C	Length A B
-------	-------------------	---------------

Made to order

70, 90, 105	75	300 300
115, 125, 135		

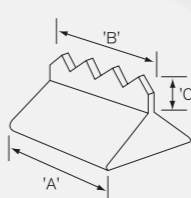

**List No. 287G**  
Two Hole Crested Gable Stop End

Angle	Crest Height C	Length A B
-------	-------------------	---------------

Made to order

75, 90, 105	125	300 300
115, 125, 135		

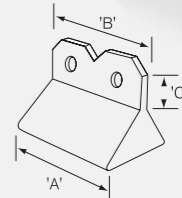

\*Length 75° - 230, 90° - 250, 105° - 265, 115° - 275, 125° - 280, 135° - 310.

Product colours



For further details on colour or pallet quantities visit [forterra.co.uk](http://forterra.co.uk)

# Scroll Finials

**List No. 271**  
Half Round Scroll Gable Finial

Span A	Length B	Height of Crest C
<b>Made to order</b>		
200, 225, 250	300	125

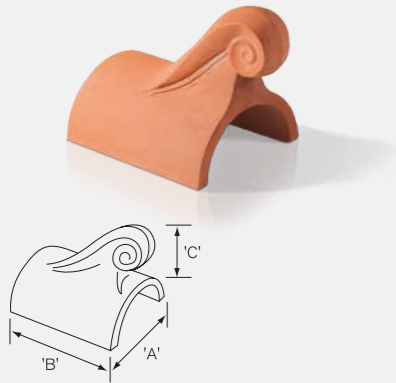

**List No. 272**  
Half Round Scroll Hip Finial

Span A	Length B	Height of Crest C
<b>Made to order</b>		
200, 225, 250	300	125

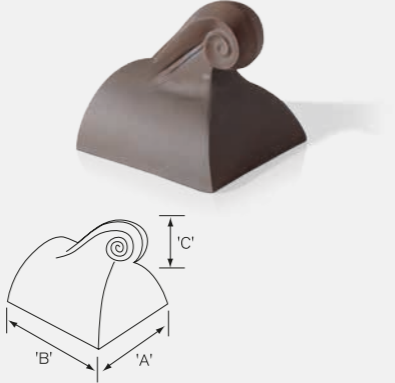

**List No. 278**  
Angled Scroll Gable Finial

Angle A	Length B	Height of Crest C
<b>Made to order</b>		
75, 90, 105 115, 125, 135	300	125

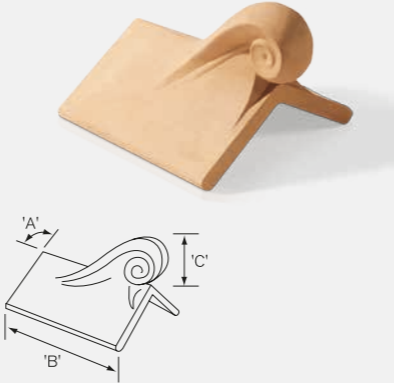

**List No. 279**  
Angled Scroll Hip Finial

Angle A	Length B	Height of Crest C
<b>Made to order</b>		
75, 90, 105 115, 125, 135	300	125

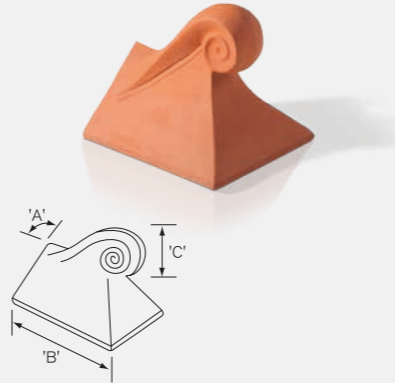

**List No. 280C**  
Angled Scroll Club Crested Gable Finial

Angle A	Length B	Height of Crest C
<b>Made to order</b>		
75, 90, 105 115, 125, 135	300	125

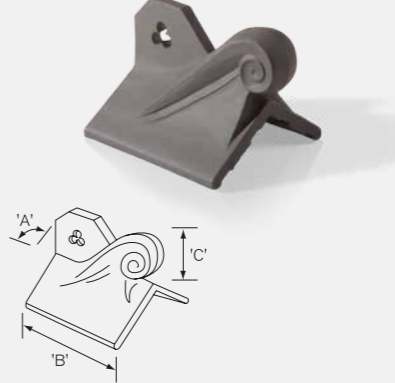

**List No. 280D**  
Angled Scroll Club Crested Hip Finial

Angle A	Length B	Height of Crest C
<b>Made to order</b>		
75, 90, 105 115, 125, 135	300	125

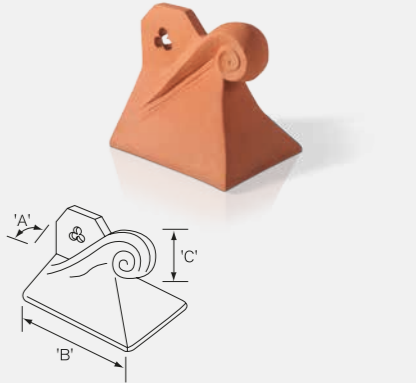

**List No. 280E**  
Angled Scroll Holed Crested Gable Finial

Angle A	Length B	Height of Crest C
<b>Made to order</b>		
75, 90, 105 115, 125, 135	300	See illustrated detail of Crested Ridge.

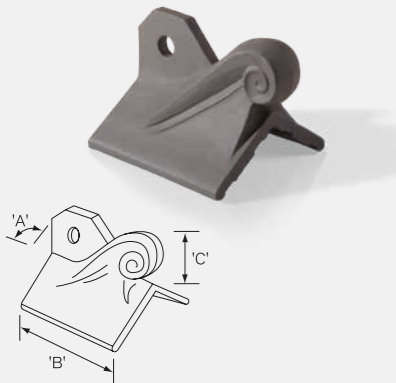

**List No. 280F**  
Angled Scroll Holed Crested Hip Finial

Angle A	Length B	Height of Crest C
<b>Made to order</b>		
75, 90, 105 115, 125, 135	300	125

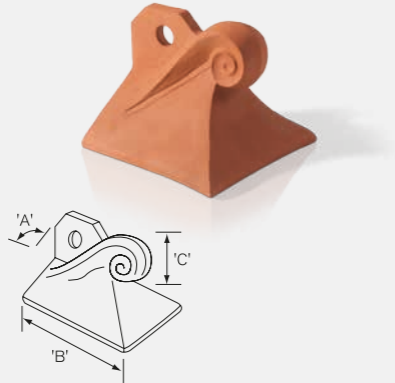

**List No. 280G**  
Angled Scroll Plain Crested Gable Finial

Angle A	Length B	Height of Crest C
<b>Made to order</b>		
75, 90, 105 115, 125, 135	300	25, 50, 75, 100, 125 applicable to all angles.

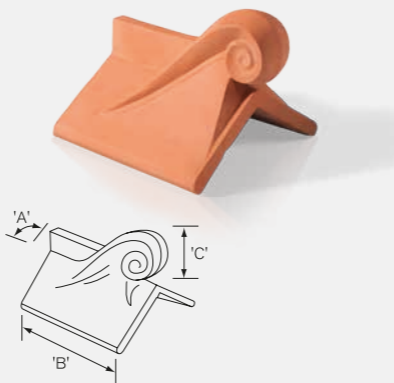

**List No. 280H**  
Angled Scroll Plain Crested Hip Finial

Angle A	Length B	Height of Crest C
<b>Made to order</b>		
75, 90, 105 115, 125, 135	300	25, 50, 75, 100, 125 applicable to all angles.

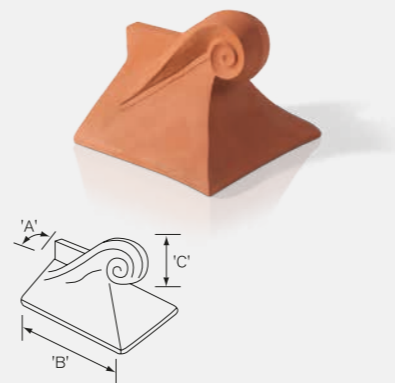

**List No. 280J**  
Angled Scroll Cocks Comb Gable Finial

Angle A	Length B	Height of Crest C
<b>Made to order</b>		
75, 90, 105 115, 125, 135	300	125

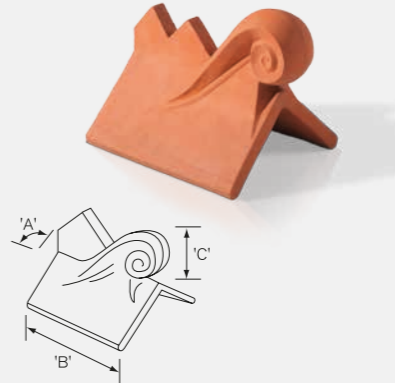

**List No. 280K**  
Angled Scroll Cocks Comb Hip Finial

Angle A	Length B	Height of Crest C
<b>Made to order</b>		
75, 90, 105 115, 125, 135	300	125

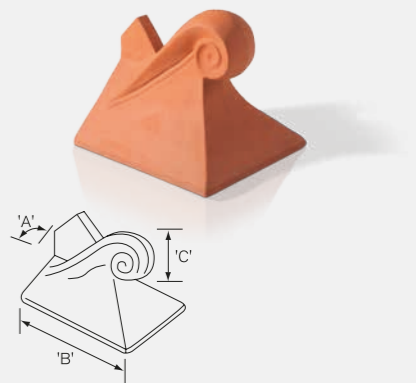

**Product colours**  
 Red
  Buff
  Slate Bodymix

For further details on colour or pallet quantities visit [forterra.co.uk](http://forterra.co.uk)

# Finials

**List No. 282G**

Fleur-de-Lys Gable Finial

Nominal Height	Angle B
275	75, 90, 105, 115, 125, 135

Made to order

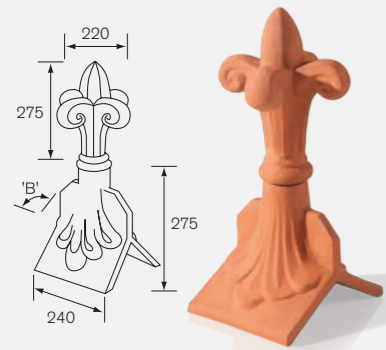

**List No. 282H**

Fleur-de-Lys Hip Finial

Nominal Height	Angle B
275	75, 90, 105, 115, 125, 135

Made to order

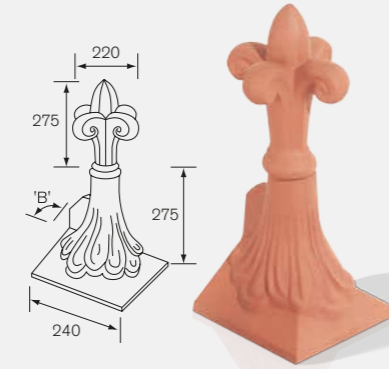

**List No. 283G**

Ball Top Gable Finial

Nominal Height	Angle B
335	75, 90, 105, 115, 125, 135

Made to order

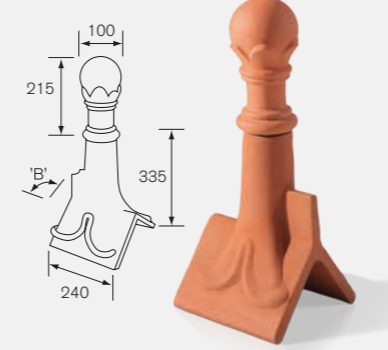

# Finial Bases & Accessories

**List No. 291G**

Angled Gable Stop End Finial Base

Length A	Angle B
300, 450	75, 90, 105, 115, 125, 135

Made to order

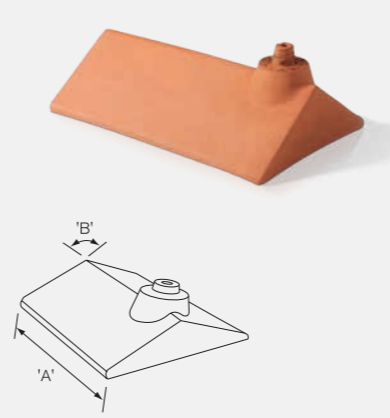

**List No. 291H**

Angled Hip Stop End Finial Base

Length A	Angle B
300, 450	75, 90, 105, 115, 125, 135

Made to order

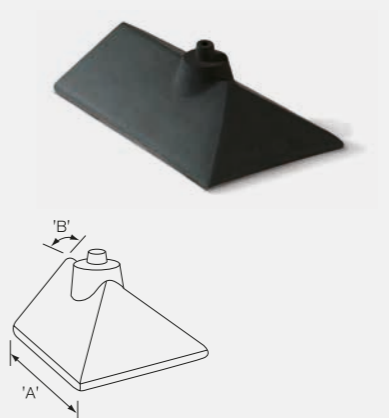

**List No. 294**

Ridge Finial Base

Length A	Angle B
300, 450	75, 90, 105, 115, 125, 135

Made to order

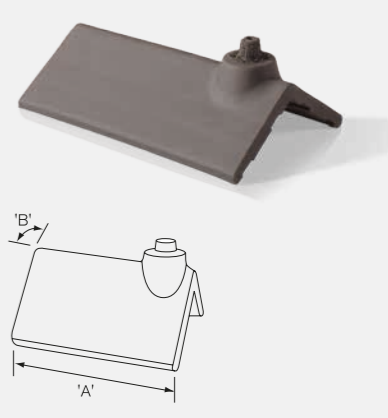

**List No. 283H**

Ball Top Hip Finial

Nominal Height	Angle B
335	75, 90, 105, 115, 125, 135

Made to order

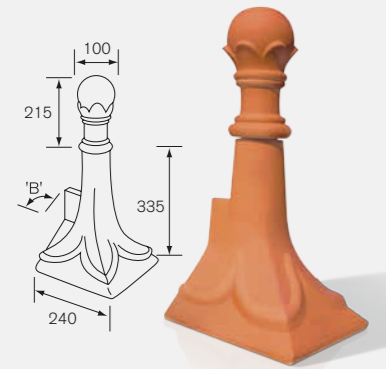

**List No. 282T**

Large Fleur-de-Lys Top

Made to order  
See illustrated detail

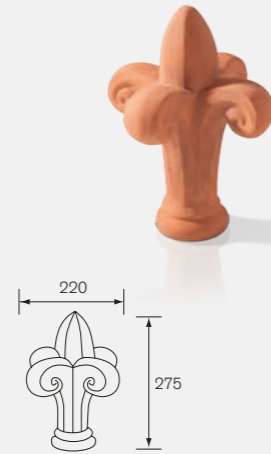

**List No. 283T**

Large Ball Top

Made to order  
See illustrated detail

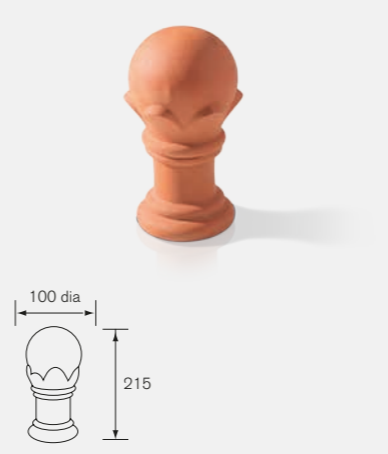

**List No. 317**

Half Round Ridge Finial Base

Length A	Span (int. dia.) B
300	200, 225

Made to order

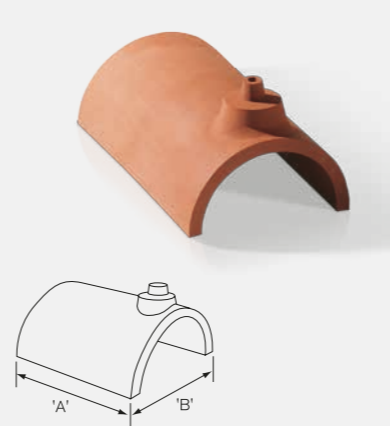

**List No. 327G**

Half Round Gable Stop End Finial Base

Length A	Span (int. dia.) B
300	200, 225

Made to order



**List No. 327H**

Half Round Hip Stop End Finial Base

Length A	Span (int. dia.) B
300	225

Made to order

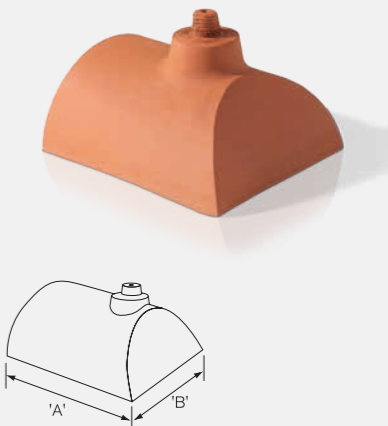

Product colours



For further details on colour or pallet quantities visit [forterra.co.uk](http://forterra.co.uk)

# Finial Bases & Accessories

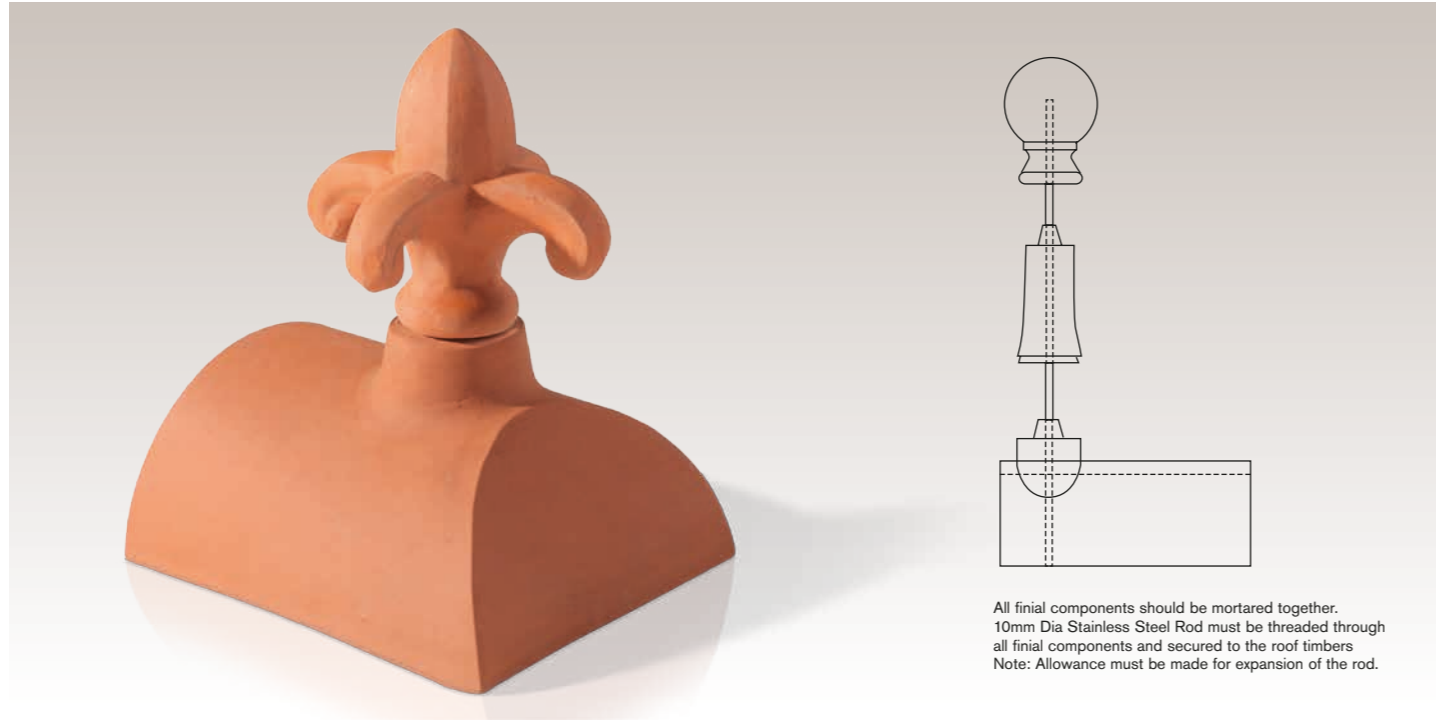

All finial components should be mortared together. 10mm Dia Stainless Steel Rod must be threaded through all finial components and secured to the roof timbers. Note: Allowance must be made for expansion of the rod.

**List No. 292**  
125mm high Extension Piece

Made to order  
See illustrated detail

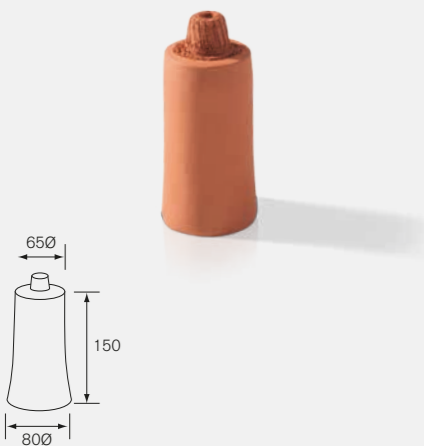

**List No. 293**  
125mm high Small Ball Top

Made to order  
See illustrated detail

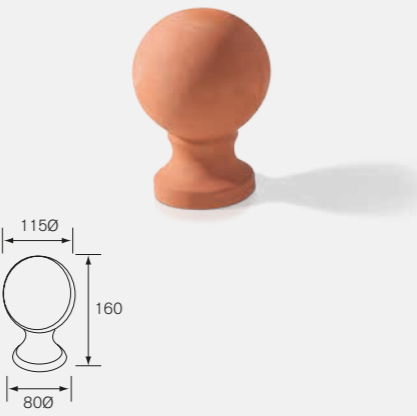

**List No. 295**  
150mm high Small Fleur-de-Lys Top

Made to order  
See illustrated detail

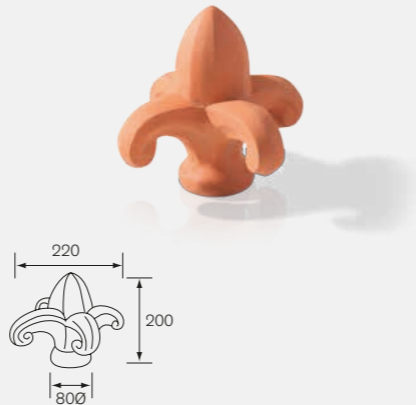

**Product colours**  
 Red
  Buff
  Slate Bodymix

For further details on colour or pallet quantities visit [forterra.co.uk](http://forterra.co.uk)

# Dry Fix Ridge System

Red Bank's universal dry fixed ventilated ridge and hip system is manufactured entirely from aluminium, it overcomes the durability and weathering problems associated with other fabric based roll ridge systems.

- All aluminium construction
- Suits all tile profiles including all ridge and hip tile designs
- Quick and easy to install
- Ventilated and driving rain resistant
- Available in grey or terracotta, 300mm wide
- Handy 6m pack

Our system stands above all other dry fixed ridge systems in its class. An innovative new product, which has a no union design allowing a completely uninterrupted air flow, yet maintaining total water resistance.

Exploiting the properties of coated aluminium gives our system market leading performance. Builders benefit from its AA fire rating enabling unrestricted use, fitting a majority of ridges and excellent design life in excess of 30 years.

The coated aluminium used is a durable, lightweight, malleable metal which is remarkable in its ability to resist corrosion. It has no need for cumbersome ridge unions to seal the gaps between the ridge tiles, which enable full ventilation to be achieved, even on slate roofs.

Red Bank's Dry Fix Ridge System gives builders the ability to meet Building Regulations Approved Document C 2004 which stipulates requirements for resistance to moisture penetration, and BS 5250-2011 which defines the level of air openness required of the roof covering. Install continuously to provide ventilation area equivalent to 5000mm<sup>2</sup>/m<sup>2</sup>.

Available as a handy 6m pack in either terracotta or grey, and is ideal for most applications. Stainless steel clips provide mechanical fixing and even ridge tile spacing.



# Dry Fix Ridge Fixing Instructions

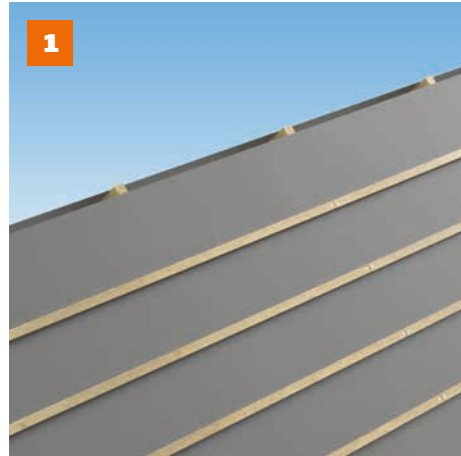

1. For unventilated dry ridge applications, install the underlay as normal. For ventilated dry ridge applications, lay the underlay ensuring it is set back 30mm short of the apex on both sides of the roof, to allow for ventilation. Don't fix top tiling batten at this stage.

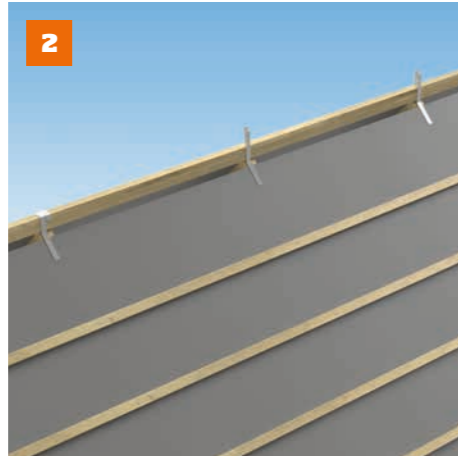

2. Fix galvanised ridge batten straps to each truss or rafter using clout nails. Using 25mm tiling battens make the ridge batten. For most tile profiles two to three battens will suffice. An extra batten may be necessary if a ridge board already exists. Secure the battens in place with ridge batten strap supplied, overlapping the arms as necessary. Fix with clout head nails.

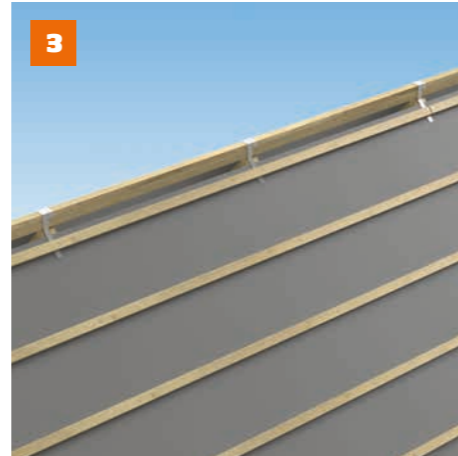

3. Fix the top tiling batten ensuring an air gap is maintained. Complete tiling as normal.

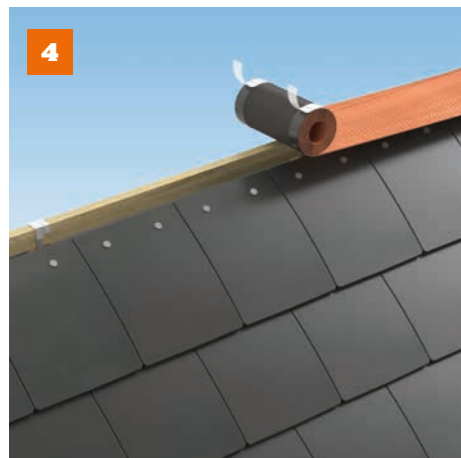

4. Unroll the Dry Fix Ventilated Ridge & Hip System centrally over the ridge batten, ensuring a 75mm overlap on each side of the top course of tiles. Secure in place every 300mm with clout nails or staples. Any joints should be overlapped by a minimum of 75mm.

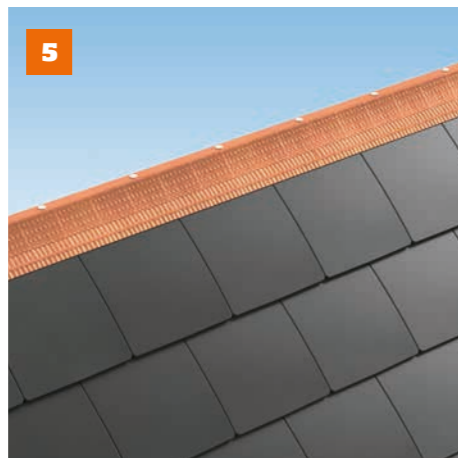

5. Remove protective paper from the adhesive strip and press down firmly onto dry, clean tiles all the way along the ridge. For deeply profiled tiles, additional care is needed to work the Dry Fix Ventilated Ridge & Hip System into the pans.

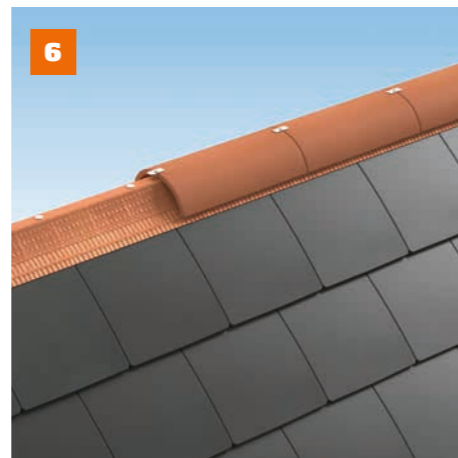

6. Locate the block end ridge tile over the centre of the roll and secure it with a screw (it may be necessary to drill a hole in the ridge approximately 30-40mm from the block end for this purpose). Continue along the ridge, fixing each ridge tile with the plates and screws provided. An optional screw sleeve is included if the user perceives that there may be a risk of light bleed between ridge tiles.

# Dry Fix Hip Fixing Instructions



1. For unventilated dry hip applications, install the underlay as normal. For ventilated dry hip applications, lay the underlay and battens, cutting the underlay 30mm short of the hip on both sides of the hip, to allow for ventilation. Ensure the ends of the battens are securely fixed where they meet the hip.



2. Hip batten supports in 50mm x 50mm timber should be screw fixed at the eaves and apex, and spaced along the line of the hip rafter, in between the tiling batten spaces as shown. Supports could be constructed from 2 x 25mm tiling battens.

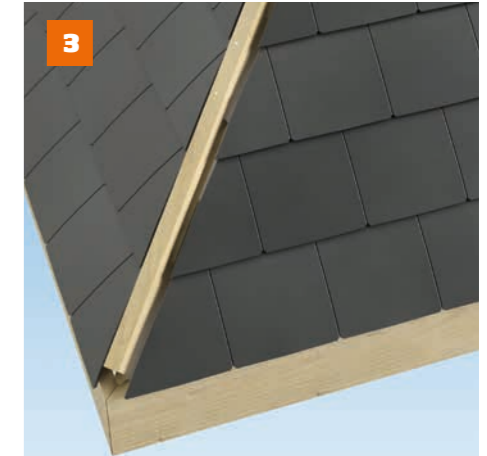

3. Screw fix hip batten constructed from 50 x 50mm timber to the supports. Complete tiling, cutting the tiles neatly against the hip batten. No cut tiles should be more than 30mm from the hip batten. Small tile cuts should be secured mechanically or by using a proprietary adhesive or other fixing method.

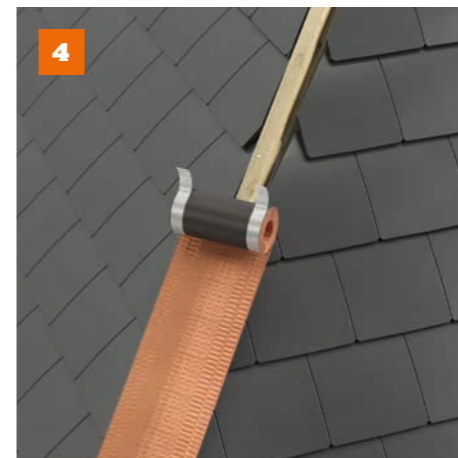

4. Working from the eaves, secure the Dry Fix Ventilated Ridge & Hip System in place centrally over the hip batten using corrosion resistant nails or staples. Roll out along the hip batten and fix at 300mm centres. Remove protective paper from the adhesive strip and press down firmly onto dry, clean tiles all the way up both sides of the hip. A hip carrier is available to assist with aligning the hip tiles when used with profiled tiles (available to order separately).

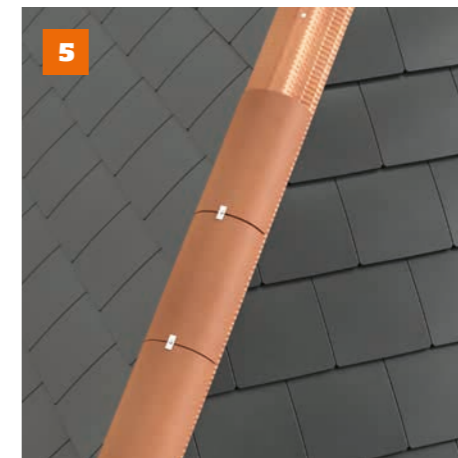

5. Using a 100mm screw provided, secure the block end hip tile to the hip batten (it may be necessary to drill a hole in the hip tile approximately 30-40mm from the block end for this purpose). Fix hip tiles up to the apex using the 100mm screws and fixing plates provided. An optional screw sleeve is included if the user perceives that there may be a risk of light bleed between hip tiles.

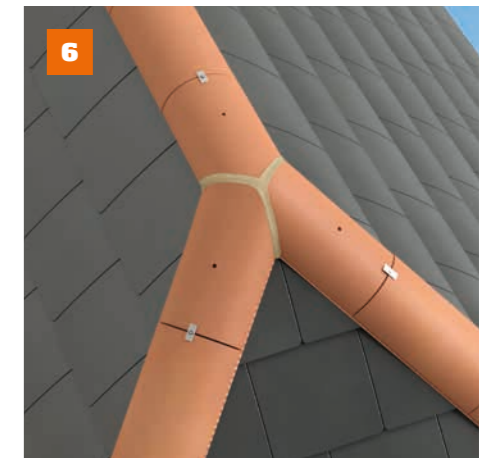

6. At the apex close mitre the hip and ridge tiles, drill and secure to the hip and ridge batten using the 100mm screws provided. If the Dry Fix Ventilated Ridge & Hip System is not used on the ridge, continue the roll 200mm onto the ridge, in place of the standard lead saddle detail.

# Suitability & Application Notes

The design profile and outlet dimensions of the chimney pot or flue terminal should preferably equate to the shape and cross sectional area of the flue lining.

Minimum recommended dimensions are dependent on the size of the fireplace opening, size of the flue lining or appliance outlet, and the type of fuel and/or appliance.

**Chimney pots and flue terminals suitable for use with solid fuel open fires and closed appliances**

Fireplaces with an opening of up to 500mm x 550mm: minimum 200mm diameter or equivalent square/rectangular cross sectional area with no dimension less than 175mm.

Fireplaces with an opening in excess of 500mm x 550mm: flue and terminal outlet equivalent to 15% of the area of the fireplace opening with no dimension less than 200mm.

Closed Appliance up to 20kW rated output: minimum 125mm diameter or equivalent square/rectangular cross sectional area, with no dimension less than 100mm on straight flues or 125mm on flue with bends or offsets.

Closed Appliance up to 30kW rated output: minimum 150mm diameter or rectangular/square cross sectional area with no dimension less than 125mm.

**Chimney pots and flue terminals suitable for use with natural draft open-flued gas burning appliances**

Flue sizes up to 170mm diameter should be fitted with an approved gas terminal complying with BS 715:1993 and BS 1289-1:1986 as shown on pages 21 and 22. Flue sizes in excess of 170mm diameter may be fitted with suitable terminals to prevent ingress if the total free area of the outlets is at least twice the cross-sectional area of the flue.

## Chimneys

Page	List no.	Description/size	Limited application	Suitable application
7	150	Blanked Roll Top	Not suitable for use with any live flue, does not provide ventilation	Suitable for dummy/prefabricated chimneys and blanking off only
8	175	150mm int. dia. top	Not suitable for use with solid fuel open fires or gas appliances	May be used with solid fuel, closed or oil fired appliances, dependent on the size of the flue and area of the flue outlet
9	36	175mm int. dia. top	Not suitable for use with solid fuel open fires	May be used with solid fuel, closed appliances and oil fired appliances, dependent on the size of the flue and area of the flue outlet
9	39	150mm int. dia. top	Not suitable for use with solid fuel open fires and gas appliances	May be used with solid fuel, closed appliances and oil fired appliances, dependent on the size of the flue and area of the flue outlet
9	53	With fixed hood	Not suitable for use with any live flue	For ventilation only
10	81	180mm int. dia. top	Traditional pattern has been used extensively with solid fuel open fires, internal top dimension does not meet current recommendations	May be used with solid fuel, closed and oil fired appliances, dependent on the size of the flue and area of the flue outlet
11	69	160mm int. sq. top	Not suitable for use with solid fuel open fires or gas appliances	May be used with solid fuel, closed and oil fired appliances, dependent on the size of the flue and area of the flue outlet
15	58	150mm int. dia. top	Not suitable for solid fuel open fires or gas appliances	May be used with solid fuel, closed appliances and oil fired appliances, dependent on the size of the flue and area of the flue outlet
15	60	175mm int. dia. top	Traditional pattern has been used extensively with solid fuel open fires, internal top dimension does not meet current recommendations, but total cross section area of outlets in excess of equivalent 200mm int. dia.	May be used with solid fuel, closed appliances and oil fired appliances, dependent on the size of the flue and area of the flue outlet
15	6	185mm int. dia. barrel	Traditional pattern has been used extensively with solid fuel open fires, internal top dimension does not meet current recommendations	May be used with solid fuel, closed appliances, gas and oil fired appliances, dependent on the size of the flue and area of the flue outlet
16	59	185mm int. dia. outlet	Has been used extensively with solid fuel open fires, internal outlet dimension does not meet current recommendations	May be used with solid fuel, closed appliances, gas and oil fired appliances, dependent on the size of the flue and area of the flue outlet
16	60	175mm int. dia. top Traditional pattern	Traditional pattern has been used extensively with solid fuel open fires, internal top dimension does not meet current recommendations, but total cross section area of outlets in excess of equivalent 200mm int. dia.	May be used with solid fuel, closed appliances and oil fired appliances, dependent on the size of the flue and area of the flue outlet
17	91	175mm int. dia. top	Not suitable for solid fuel open fires	May be used with solid fuel, closed appliances, gas and oil fired appliances, dependent on the size of the flue and area of the flue outlet

# Suitability & Application Notes

**Chimney pots and flue terminals suitable for use with oil burning appliances**

Minimum dimensions should be the same size or equivalent to the cross-sectional area of the appliance flue outlet. Suitable terminals may be used to prevent ingress if the total free area of the outlets is at least twice the cross-sectional area of the flue.

The majority of chimney pots and flue terminals included on pages 6-25 are suitable for use with solid fuel open fires and appliances, dependent on the cross-sectional area of the outlet.

Some traditional patterns may not meet all current requirements but have time proven performance characteristics.

Owing to the diversity in design and varied application, the notes provided on limited and suitable application are for guidance only. Specifiers and installers must ensure that all products are suitable for the intended application and meet all appropriate regulations and installation requirements.

If further assistance is required please contact Red Bank's Technical Services Department on 0330 123 1018.

## Inserts

Page	List no.	Description/size	Limited application	Suitable application
21	30	Hood Top	Not suitable for use with any live flue serving solid fuel open fire or closed appliance, gas or oil fired appliance	For ventilation only
21	103	Hood Top (square spigot)		
21	116	Weatherguard Top		
21	117	Blank Stopper	Not suitable for use with any live flue, does not provide ventilation	For blanking off only
22	118	Mushroom Top	Not suitable for use with any live flue serving solid fuel open fire or closed appliance, gas or oil fired appliance	For ventilation only
22	119	Mushroom Top (outside fitting)		
22	120	Flue Ventilator		

## Gas Flue Terminals

Page	List no.	Description/size	Limited application	Suitable application
23	613	GC3 Insert	Not suitable for use with decorative fuel effect gas fires and inset live fuel effect gas fires requiring minimum 175mm flue or solid fuel open fires and appliances	May be used with all types of approved gas fired appliances with flue outlet up to 150mm dia.
23	625	GC5 Insert	Not suitable for use with decorative fuel effect gas fires and inset live fuel effect gas fires, requiring minimum 175mm dia. flue or solid fuel open fires and appliances	May be used with all types of approved gas fired appliances including standard radiant gas fires with flue outlets up to 125mm dia. outlet and some inset live fuel effect gas fires, classified by appliance manufacturer as suitable for use with Class 2 flue blocks
23	636	GC10 Clay Can	Not suitable for use with decorative fuel effect gas fires and inset live fuel effect gas fires, requiring minimum 175mm dia. flue or solid fuel open fires and appliances	May be used with all types of approved gas fired appliances including standard radiant gas fires with flue outlets up to 125mm dia. outlet where flue way has been lined with 125mm int. dia. flexible metal liner
24	145	DFE Pot	Not suitable for use with Class 2 flue blocks or where gas flue way has been reduced to less than 175mm int. dia.	Suitable for use with decorative fuel effect gas fires and inset live fuel effect gas fires requiring minimum 175mm int. dia. flue, maximum recommended flue size 225mm int. dia. or equivalent square section. May also be used with solid fuel open fires to help reduce rain penetration
24	147	DFE Pot with Birdguard		
25	146	DFE Insert 215mm ext. dia. and 210mm ext. square spigot	Not suitable for use with Class 2 flue blocks or where gas flue way has been reduced to less than 175mm int. dia. solid fuel open fires or where flue terminal is less than 225mm int. dia.	Suitable for use with decorative fuel effect gas fires and inset live fuel effect gas fires requiring minimum 175mm int. dia. flue, maximum recommended flue size 225mm int. dia. or equivalent square section
25	148			
25	146	DFE Insert 235mm, 270mm ext. dia. and 235mm, 270mm ext. square spigot	Not suitable for use with Class 2 flue blocks or where gas flue way has been reduced to less than 175mm int. dia.	Suitable for use with decorative fuel effect gas fires requiring minimum 175mm int. dia. flue. May also be used with larger flue sizes dependent on the appliance manufacturers recommendations, the internal/external dimension of the spigot and solid fuel open fires, dependent on the flue size, to help reduce rain penetration
25	148			
25	149	DFE Pot Circular Base with Birdguard	Not suitable for use with Class 2 flue blocks or where gas flue way has been reduced to less than 175mm int. dia.	Suitable for use with decorative fuel effect gas fires requiring minimum 175mm int. dia. flue. May also be used with larger flue sizes dependent on the appliance manufacturers recommendations and solid fuel open fires, dependent on the flue size, to help reduce rain penetration
25	149	DFE Pot Square Base with Birdguard		





**Forterra is a leading manufacturer of a diverse range of clay and concrete building products, used extensively within the construction sector, and employs over 1,900 people across 18 manufacturing facilities in the UK.**

**It is the second largest brick and aircrete block manufacturer in the country, and the only producer of the iconic London Brick. Other trusted brands from Forterra include Thermalite, Conbloc, Ecostock, Butterley, Cradley, Red Bank, Bison Precast, Jetfloor and Formpave.**

**[forterra.co.uk](http://forterra.co.uk)**

**Forterra**

Atherstone Road  
Measham  
Swadlincote  
Derbyshire, DE12 7EL

**Sales:** 01530 273 737

**Fax:** 0800 731 5944

**Email:** [redbanksales@forterra.co.uk](mailto:redbanksales@forterra.co.uk)

**[forterra.co.uk](http://forterra.co.uk)**

