



**BISON PRECAST**

a Forterra brand

# 1.00M RETAINING WALL

Drawing number: 12073-013

Note: Do not scale from this drawing. If in doubt, please ask for confirmation of any dimension.

Unit volume = 0.177 cu m

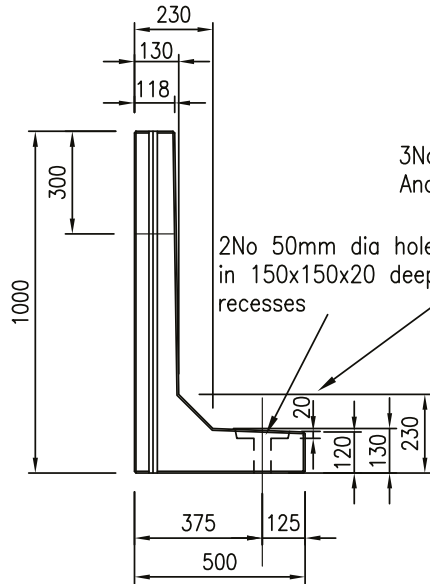

Side Elevation

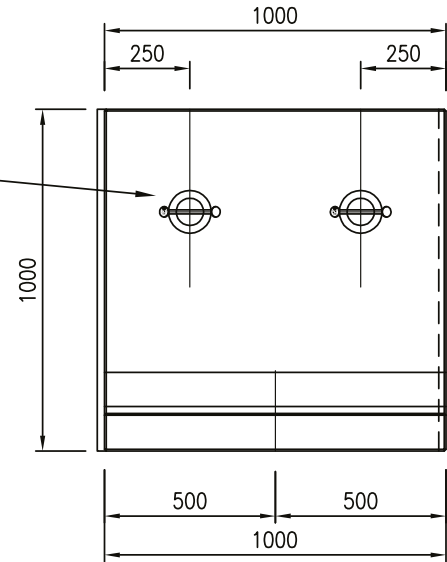

Front Elevation

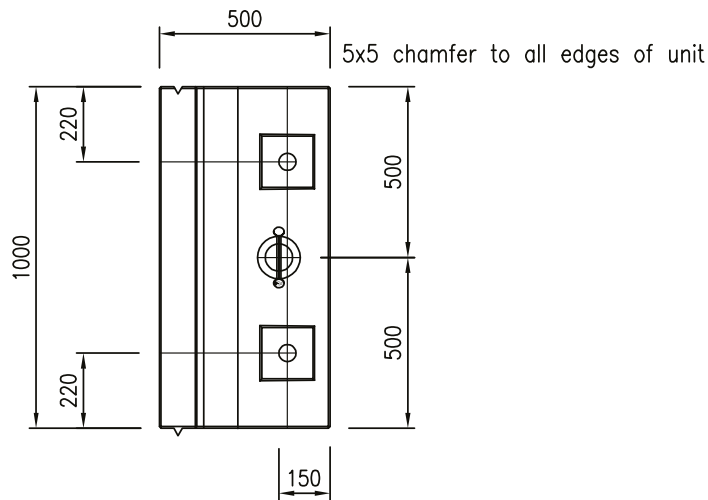

Plan

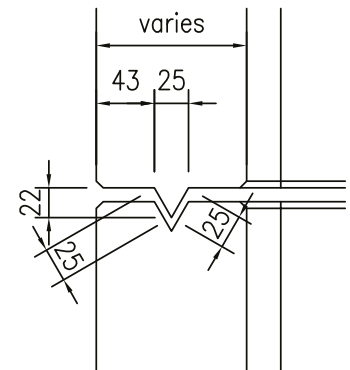

Joint Detail (1:5)

Height:	1000mm
Width:	1000mm
Depth:	500mm
Weight:	450kg
Embedment:	150mm

NOTES:

- Concrete strengths:-  
At 28 days           Min 60 N/sq mm  
At demoulding       Min 15 N/sq mm
- For reinforcement details see Drg no 12073-015.

OUR PEOPLE. OUR PASSION. OUR PRODUCTS

The components you need for a more successful project.

Bison Precast - Tetron Point - William Nadin Way - Swadlincote - Derbyshire - DE11 0BB

01283 817 500 concrete@bison.co.uk bison.co.uk



**BISON PRECAST**

a Forterra brand

# 1.00M RETAINING WALL

Ancillary Items

Note: Do not scale from this drawing. If in doubt, please ask for confirmation of any dimension.

## Loose items schedule: per 1.00m unit

No.	Item
2	M16 (Grade 8.8) Galv Althread x 340lg
2	M16 Galv Nuts
2	100 x 100 x 8thk Galv Plate washer (Ref: PW4)

Grouted in using C32/40 non-shrink grout

All loose items available direct from Bison Precast

All loose items available direct from Bison Precast.  
Please enquire for further details.

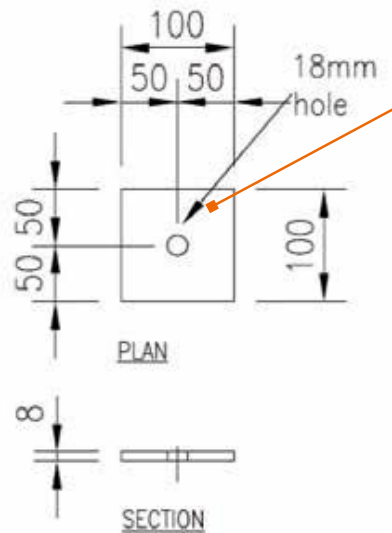
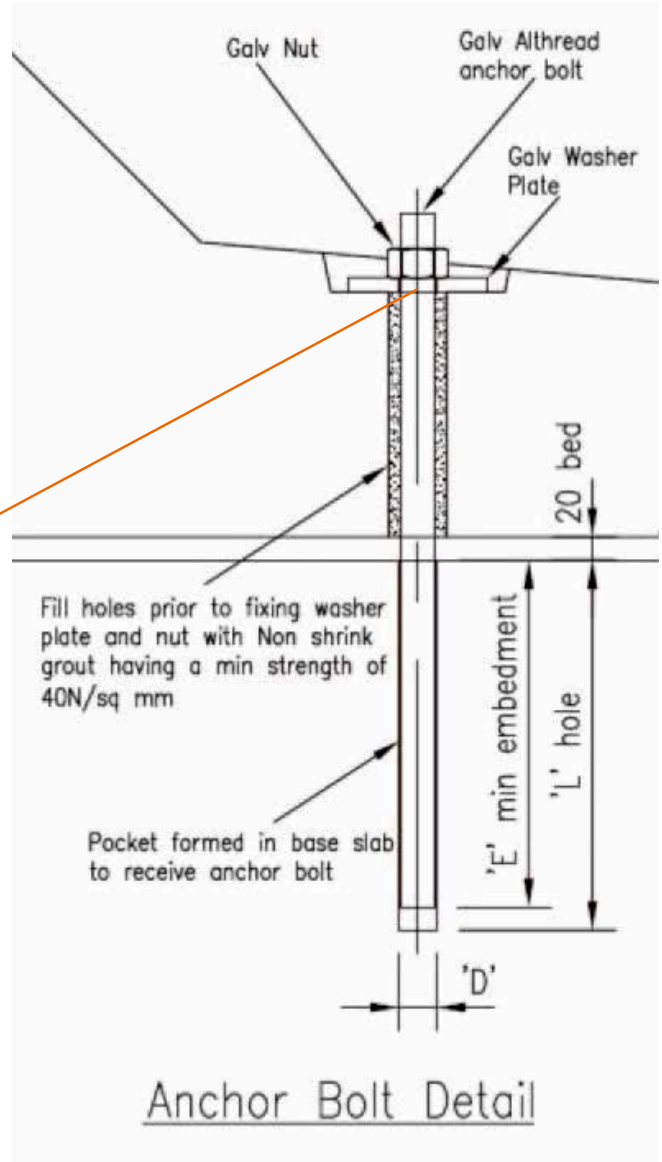

Plate Washer PW4



Anchor Bolt Detail