



BISON PRECAST

a Forterra brand

1.50M RETAINING WALL

Corner Unit - Drawing number: 60

Note: Do not scale from this drawing. If in doubt, please ask for confirmation of any dimension.

Height: 1500mm
 Width: 1000mm
 Depth: 1000mm
 Weight: 1.102t
 Embedment: 150mm

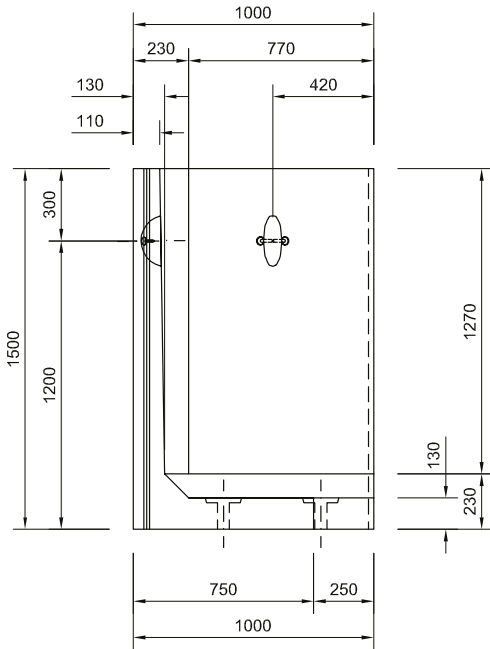

View A - A

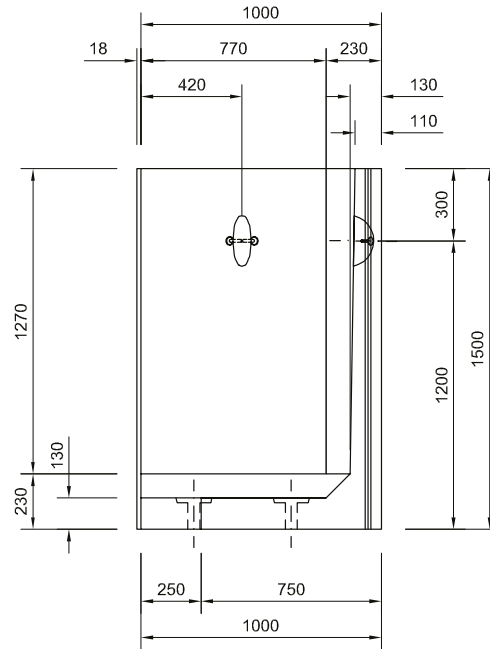

View B - B

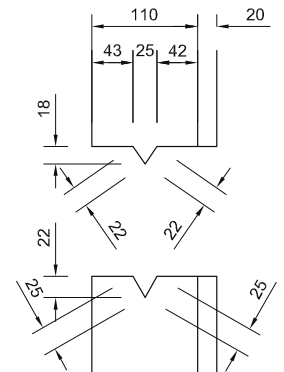

Joint Detail

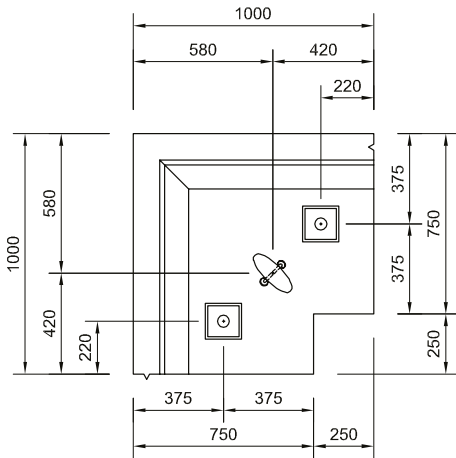

Plan

View A - A



View B - B

NOTES:

CONCRETE GRADE -
 COVER TO REINFORCEMENT -

50/60
 45mm Nominal
 (Minimum 40mm)

A	Joint detail amended slightly.	DC	17/12/12
rev	amendment	by	date
BISON PRECAST		fc	
BISON PRECAST		state	
©			
job Retaining Wall			
title Retaining Wall - 1500mm High Corner Unit			
Volume 0.441 cu.m. Weight 1.102 tonnes.			
date	02/12/2012	job no	HBP-RW
scale	1:20	drw no	60
drawn	D. Chamberlain	rev	A
checked	-		



BISON PRECAST

a Forterra brand

1.50M RETAINING WALL

Ancillary Items

Note: Do not scale from this drawing. If in doubt, please ask for confirmation of any dimension.

Loose items schedule: per 1.50m unit

No.	Item
2	M16 (Grade 8.8) Galv Althread x 340lg
2	M16 Galv Nuts
2	100 x 100 x 8thk Galv Plate washer (Ref: PW4)

Grouted in using C32/40 non-shrink grout

All loose items available direct from Bison Precast. Please enquire for further details.

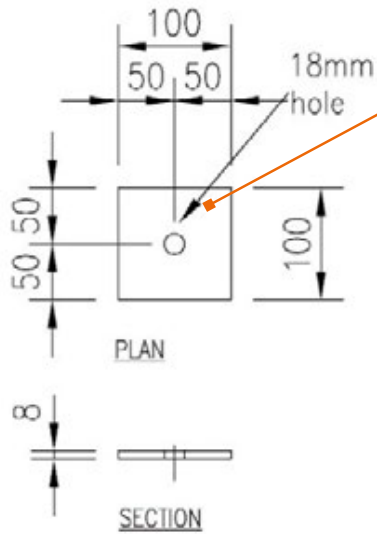
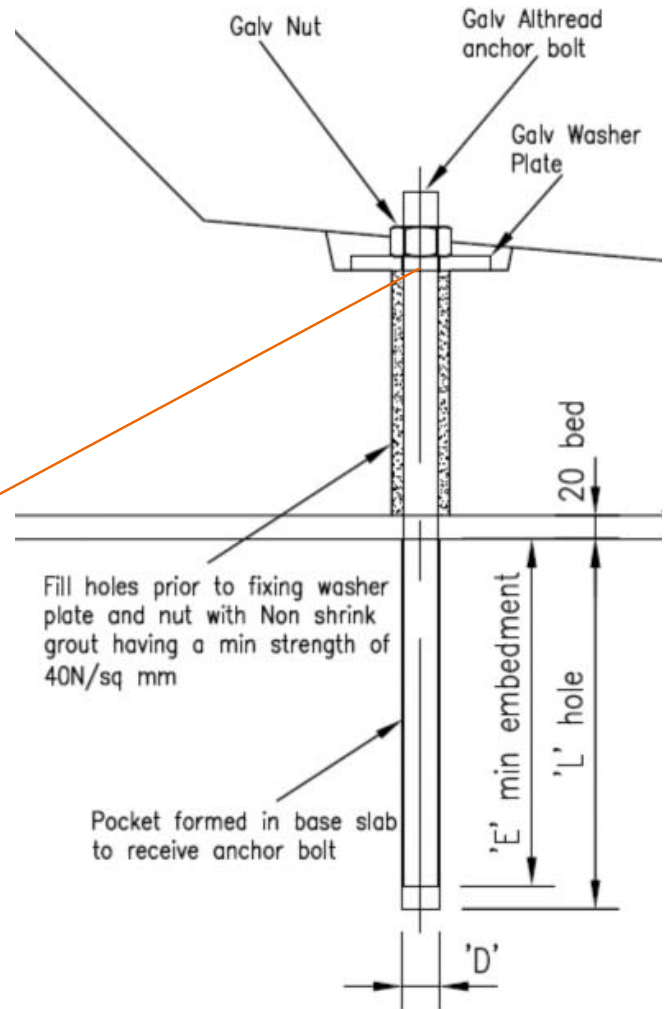

Plate Washer PW4



Anchor Bolt Detail