



BISON PRECAST

a Forterra brand

1.50M RETAINING WALL

Drawing number: 12073-017

Note: Do not scale from this drawing. If in doubt, please ask for confirmation of any dimension.

Unit volume = 0.263 cu m

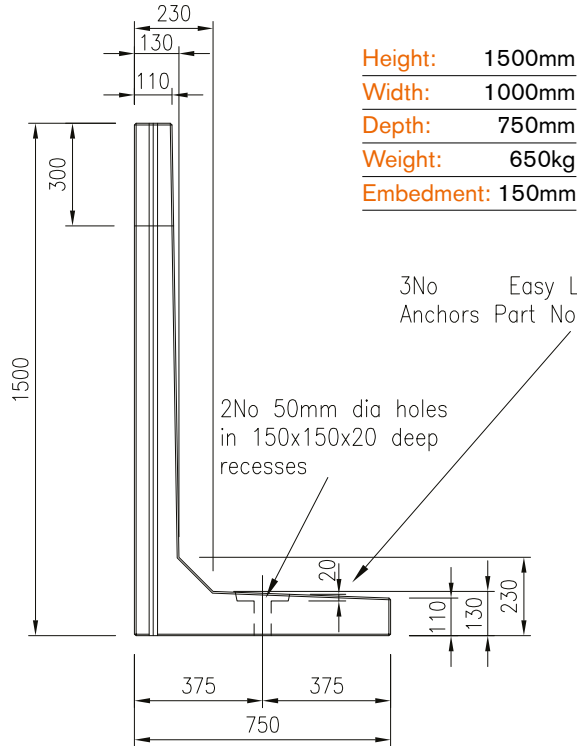

Side Elevation

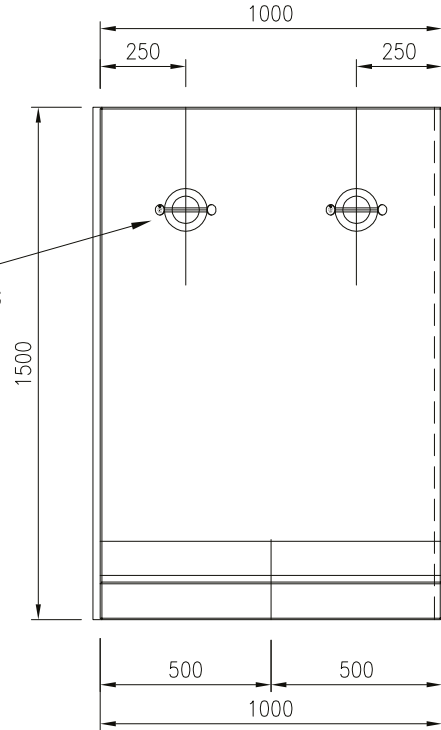

Front Elevation

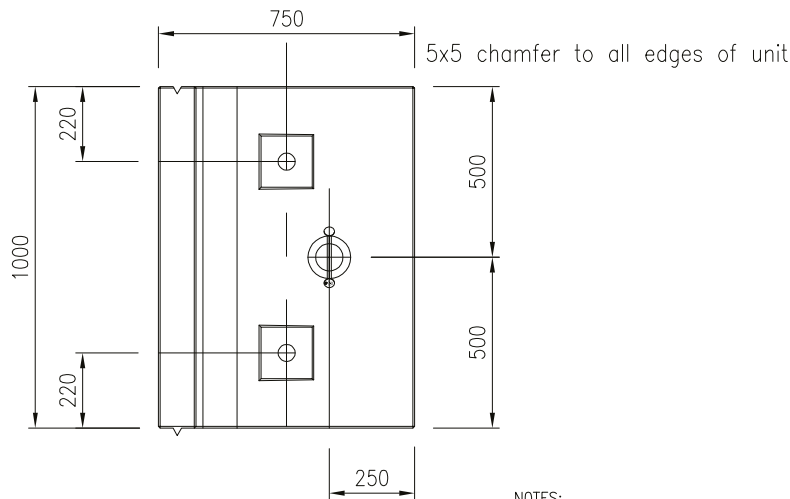

Plan

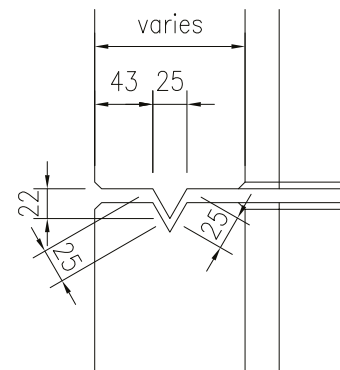

Joint Detail (1:5)

NOTES:

- Concrete strengths:-
 At 28 days Min 60 N/sq mm
 At demoulding Min 15 N/sq mm
- For reinforcement details see Drg no 12073-019.



BISON PRECAST

a Forterra brand

1.50M RETAINING WALL

Ancillary Items

Note: Do not scale from this drawing. If in doubt, please ask for confirmation of any dimension.

Loose items schedule: per 1.50m unit

| No. | Item |
|-----|---|
| 2 | M16 (Grade 8.8) Galv Althread x 340lg |
| 2 | M16 Galv Nuts |
| 2 | 100 x 100 x 8thk Galv Plate washer (Ref: PW4) |

Grouted in using C32/40 non-shrink grout

All loose items available direct from Bison Precast. Please enquire for further details.

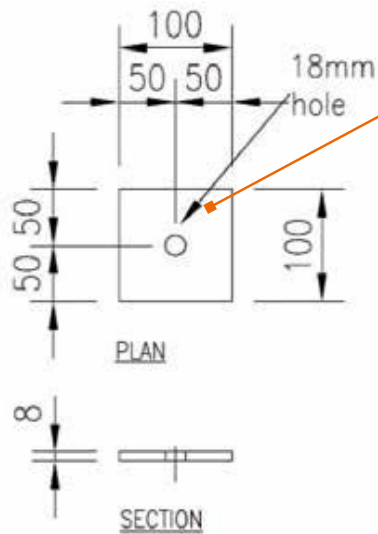
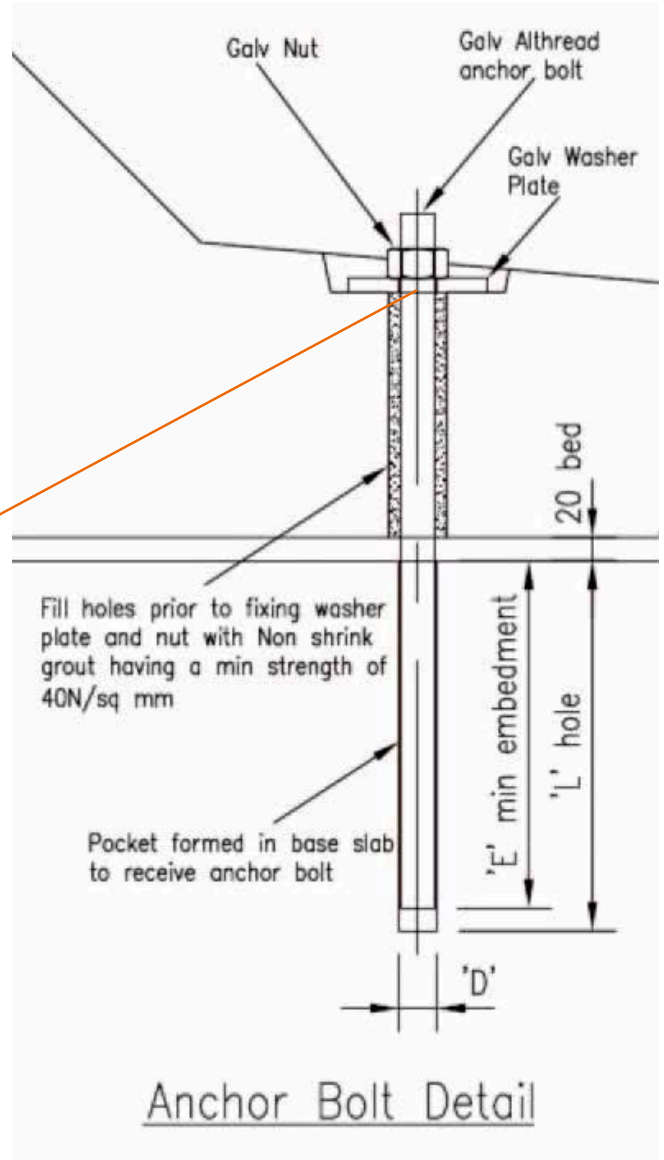

Plate Washer PW4



Anchor Bolt Detail