



**BISON PRECAST**

a Forterra brand

# 2.00M RETAINING WALL

Drawing number: 12073-005

Note: Do not scale from this drawing. If in doubt, please ask for confirmation of any dimension.

Unit volume = 0.455 cu m

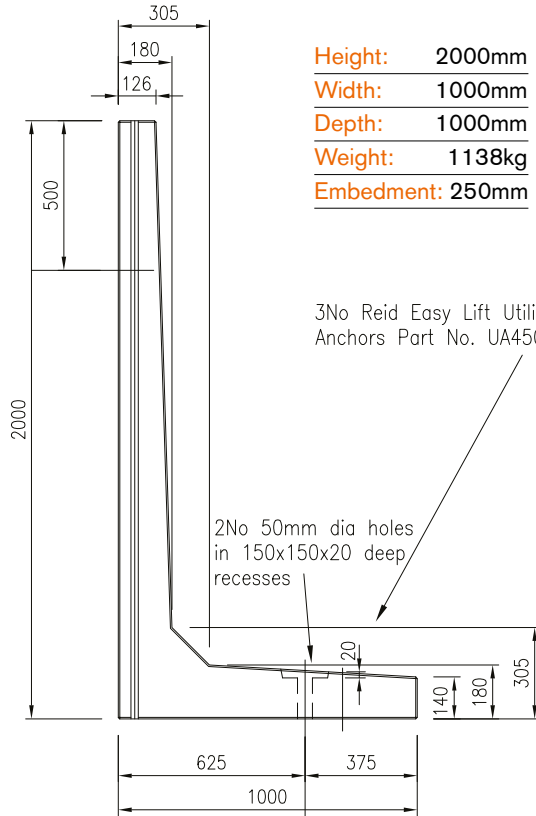

Side Elevation

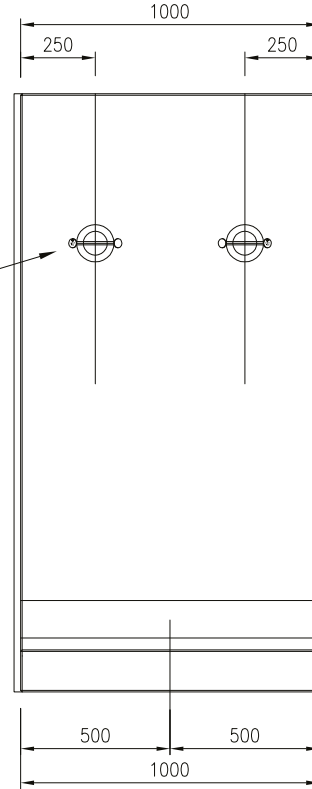

Front Elevation

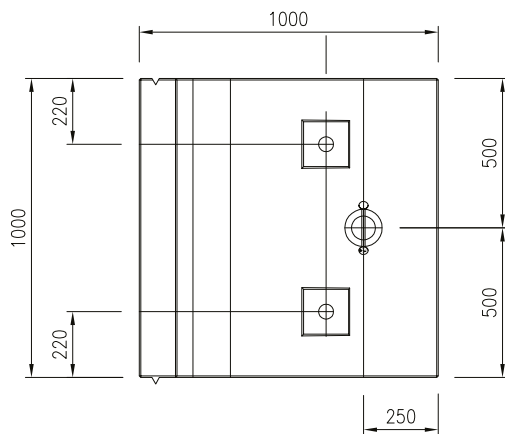

Plan

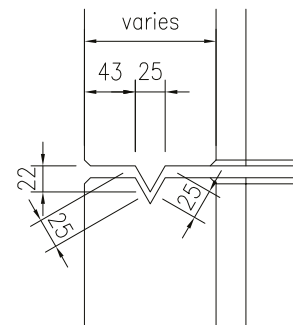

Joint Detail (1:5)

NOTES:

- Concrete strengths:-  
 At 28 days      Min 60 N/sq mm  
 At demoulding      Min 15 N/sq mm
- For reinforcement details see Drg no 12073-007.



**BISON PRECAST**

a Forterra brand

# 2.00M RETAINING WALL

Ancillary Items

Note: Do not scale from this drawing. If in doubt, please ask for confirmation of any dimension.

## Loose items schedule: per 2.00m unit

No.	Item
2	M20 (Grade 8.8) Galv Althread x 485lg
2	M20 Galv Nuts
2	100 x 100 x 10thk Galv Plate washer (Ref: PW3)

Grouted in using C32/40 non-shrink grout

All loose items available direct from Bison Precast. Please enquire for further details.

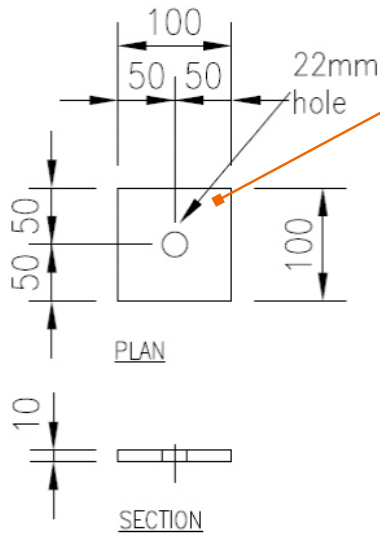
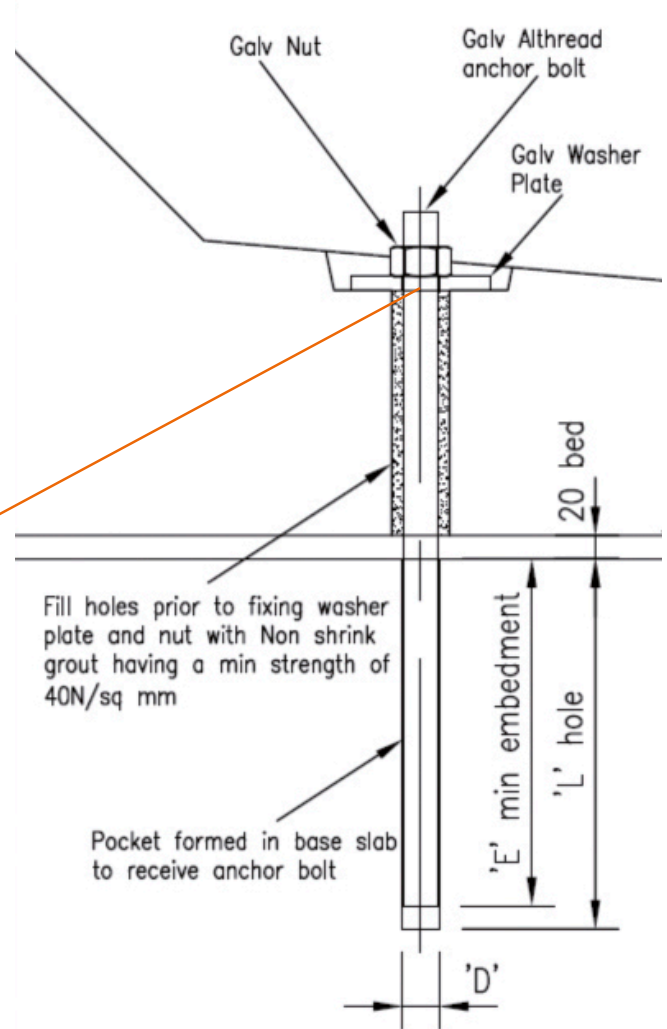

Plate Washer PW3



Anchor Bolt Detail