



BISON PRECAST

a Forterra brand

3.00M RETAINING WALL

Corner Layout - Drawing number: 200

Note: Do not scale from this drawing. If in doubt, please ask for confirmation of any dimension.

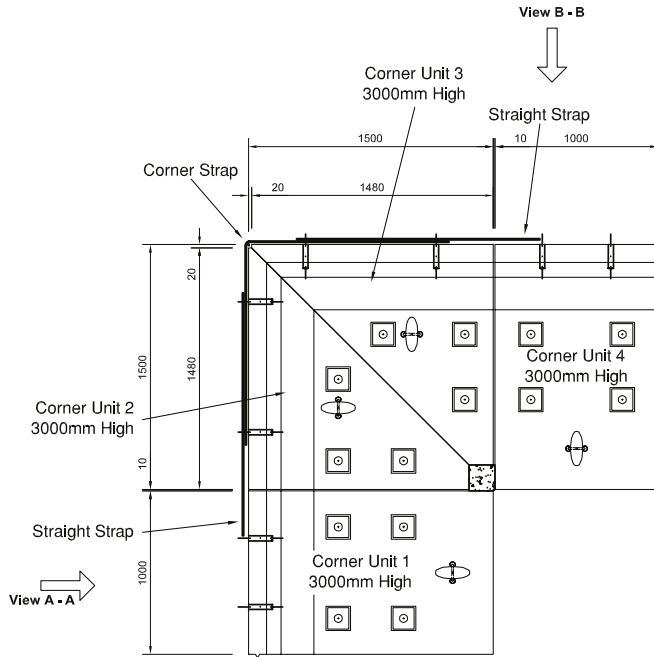

Corner Section Plan

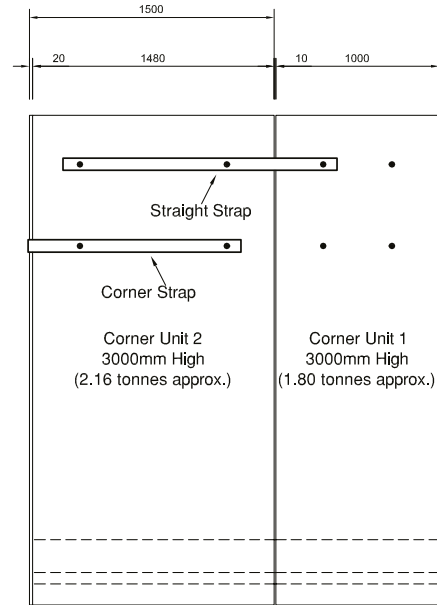

View A - A

Height: 3000mm
 Width: 2500mm
 Depth: 2500mm
 Total weight: 7.92t
 Embedment: 250mm

See individual unit details above for individual weights.

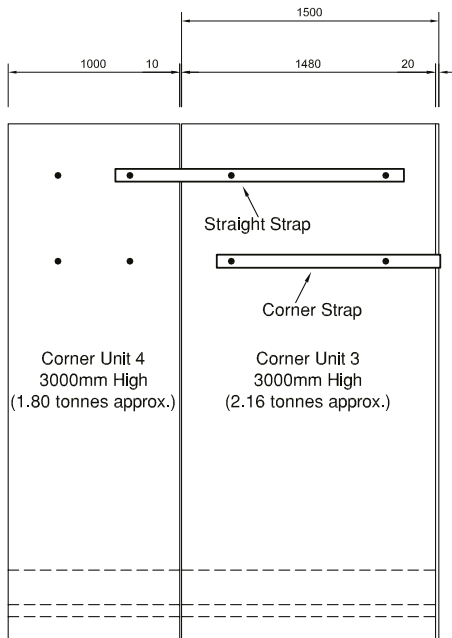

View B - B

rev	amendment	by	date
-	-	-	-
BISON PRECAST		fc	
BISON PRECAST		:state ©	
job Retaining Wall			
title Retaining Wall - 3000mm High Corner Layout			
date	05/03/2013	job no	HBP-RW
scale	1:25	drawn	D. Chamberlain
checked	-	drg no	200
		rev	-



BISON PRECAST

a Forterra brand

3.00M RETAINING WALL

Ancillary Items

Note: Do not scale from this drawing. If in doubt, please ask for confirmation of any dimension.

Loose items schedule: per 3.00m unit

No.	Item
14	M24 (Grade 8.8) Galv Althread x 510lg
14	M24 Galv Nuts
14	100 x 100 x 12thk Galv Plate washer (Ref: PW2)

Grouted in using C32/40 non-shrink grout

All loose items available direct from Bison Precast. Please enquire for further details.

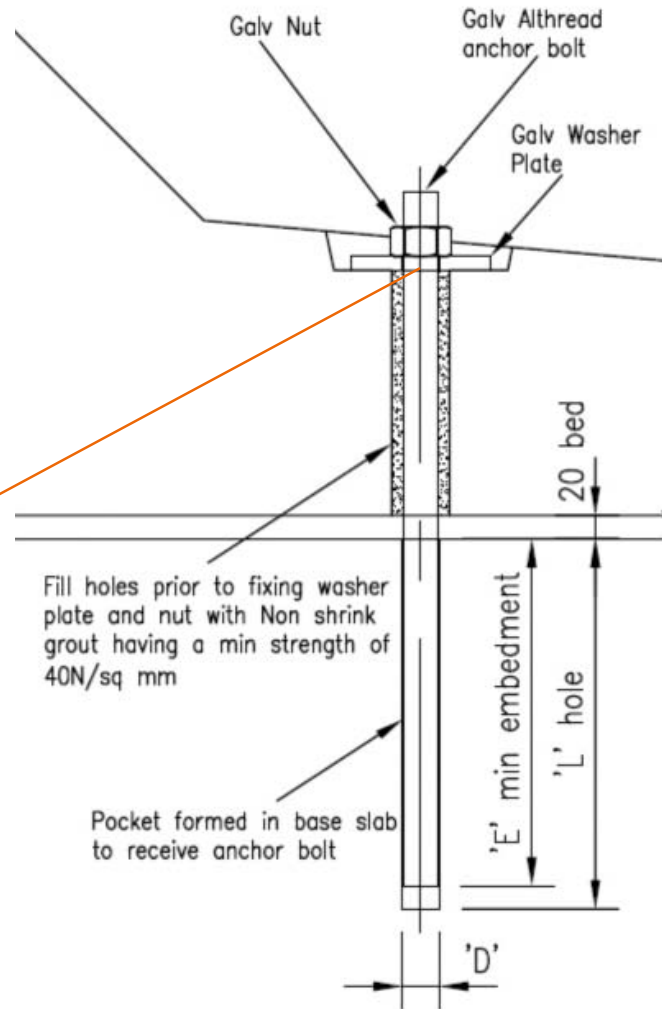
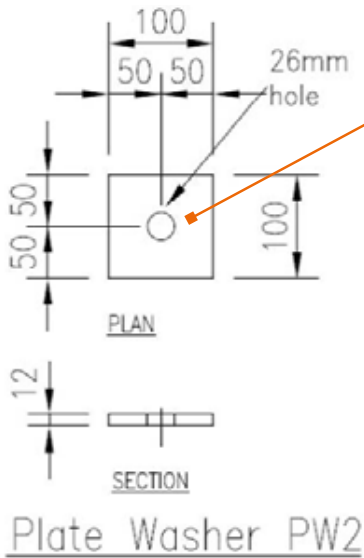

Anchor Bolt Detail