

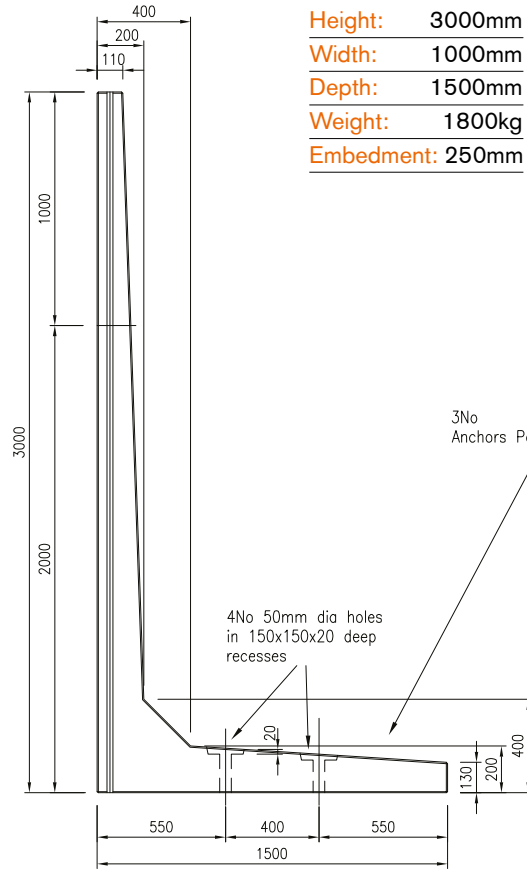

# 3.00M RETAINING WALL

Note: Do not scale from this drawing. If in doubt, please ask for confirmation of any dimension.

Unit volume = 0.724 cu m



Side Elevation

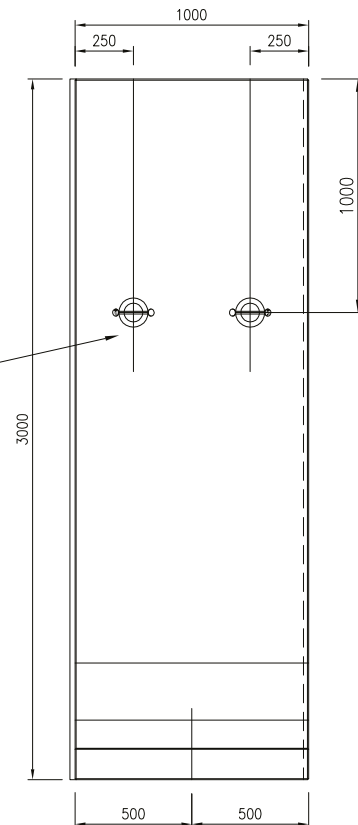

Front Elevation

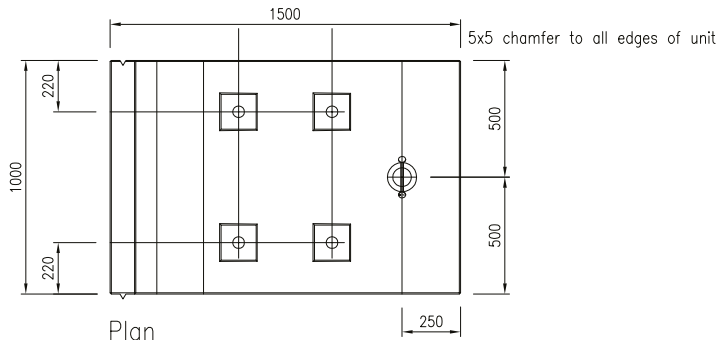

Plan

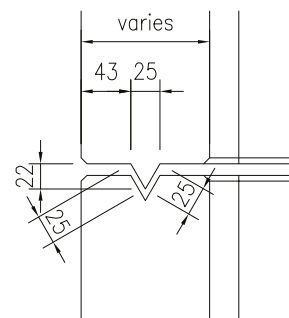

Joint Detail (1:5)

NOTES:

- Concrete strengths:-  
 At 28 days Min 60 N/sq mm  
 At demoulding Min 15 N/sq mm
- For reinforcement details see Drg no 12073-023.



**BISON PRECAST**

a Forterra brand

# 3.00M RETAINING WALL

Ancillary Items

Note: Do not scale from this drawing. If in doubt, please ask for confirmation of any dimension.

## Loose items schedule: per 3.00m unit

No.	Item
4	M24 (Grade 8.8) Galv Althread x 510lg
4	M24 Galv Nuts
4	100 x 100 x 12thk Galv Plate washer (Ref: PW2)

Grouted in using C32/40 non-shrink grout

All loose items available direct from Bison Precast. Please enquire for further details.

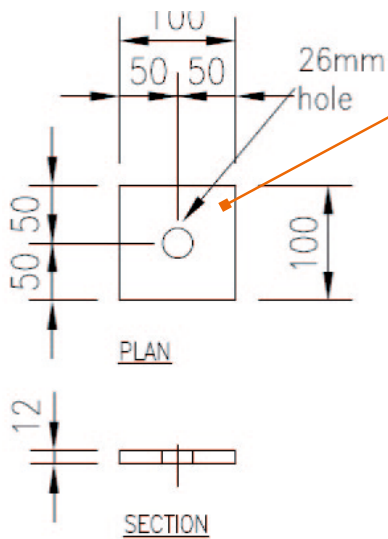
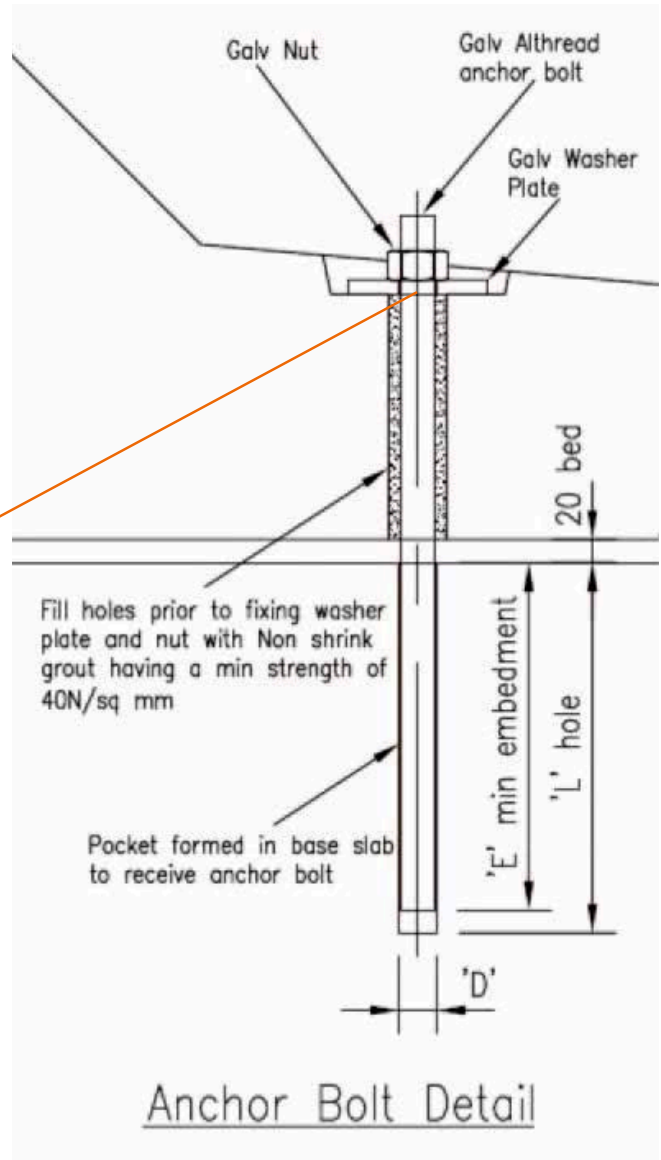

Plate Washer PW2



OUR PEOPLE. OUR PASSION. OUR PRODUCTS

The components you need for a more successful project.

Bison Precast - Tetron Point - William Nadin Way - Swadlincote - Derbyshire - DE11 0BB

01283 817 500 concrete@bison.co.uk bison.co.uk