



BISON PRECAST

a Forterra brand

INTERLOCKING JOINT

for Retaining Walls

Note: Do not scale from this drawing. If in doubt, please ask for confirmation of any dimension.

All our units are provided with a unique interlocking detail which further enhance installation times through accurate and fast alignment. The added benefits of this detail also ensure a strong and reliable connection detail which can be made water proof with the correct sealant detail. Note all units will be supplied with a male female connection detail as standard, however we are happy to provide a traditional flat joint detail to one or both ends if required.

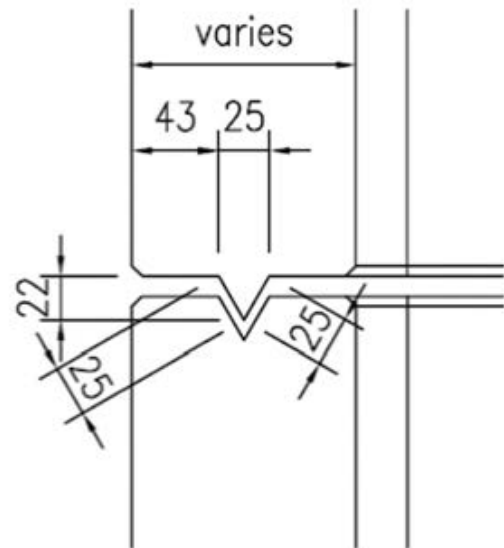

Joint Detail (1:5)

OUR PEOPLE. OUR PASSION. OUR PRODUCTS

The components you need for a more successful project.

Bison Precast - Tetron Point - William Nadin Way - Swadlincote - Derbyshire - DE11 0BB

01283 817 500 concrete@bison.co.uk bison.co.uk