



**BISON PRECAST**

a Forterra brand

# TECHNICAL GUIDANCE NOTE

Void Ventilators and Air Bricks - 1 December 2015

This Guidance Note explains the use of Void Ventilators and Air Bricks when used in conjunction with Forterra precast concrete flooring systems.

## Building Regulation Requirements

The Building Regulations 2000 Part C clause 4.19 states that a suspended concrete floor will meet the requirement if it incorporates a ventilated air space. This should measure at least 150mm clear from the ground to the underside of the floor (or insulation if provided). Two opposing external walls should have ventilation openings placed so that the ventilating air will have a free path between opposite sides and to all parts of the floor void. The openings should not be less than either 1500mm<sup>2</sup>/m run of external wall or 500mm<sup>2</sup>/m<sup>2</sup> of floor area, whichever gives the greater opening area.

## Void Ventilators and Air Bricks by Forterra

The void ventilators and air bricks supplied by Forterra:

- Are manufactured in UV stabilised polypropylene
- Satisfy all NHBC regulations
- Are manufactured to BS EN ISO9001:2000
- Comply with all relevant Building Regulations
- Meet all relevant British Standards
- The standard Ventilator (supplied by Forterra) will fit a 250mm thick cavity wall (with an external leaf of 100mm, a cavity width of 50mm and an inner leaf of 100mm). External and internal horizontal extension sleeves are available to accommodate thicker walls or wider cavities.
- Neither the Ventilator nor the Air brick provide any structural support. Provision must be made to distribute loads accordingly above the wall penetrations.

## Installation

The Ventilator and Air Brick provide 6000mm<sup>2</sup> of air flow, however it is recommended that underfloor ventilators are spaced at a maximum of 2m centres, with Ventilators also positioned not more than 450mm from the ends of the wall.

It is good practise to position Ventilators around the full perimeter of the building, particularly with complex building designs.

If the underfloor void is separated by dividing walls, openings must be provided to allow a free flow of air around the underfloor void.

Please note that the air flow of other types of Ventilators and Air Bricks may vary and therefore may affect the recommended spacings.

OUR PEOPLE. OUR PASSION. OUR PRODUCTS

The components you need for a more successful project.

Bison Precast - Tetron Point - William Nadin Way - Swadlincote - Derbyshire - DE11 0BB

01283 817 500 concrete@bison.co.uk bison.co.uk



**BISON PRECAST**

a Forterra brand

# TECHNICAL GUIDANCE NOTE

Void Ventilators and Air Bricks - 1 December 2015

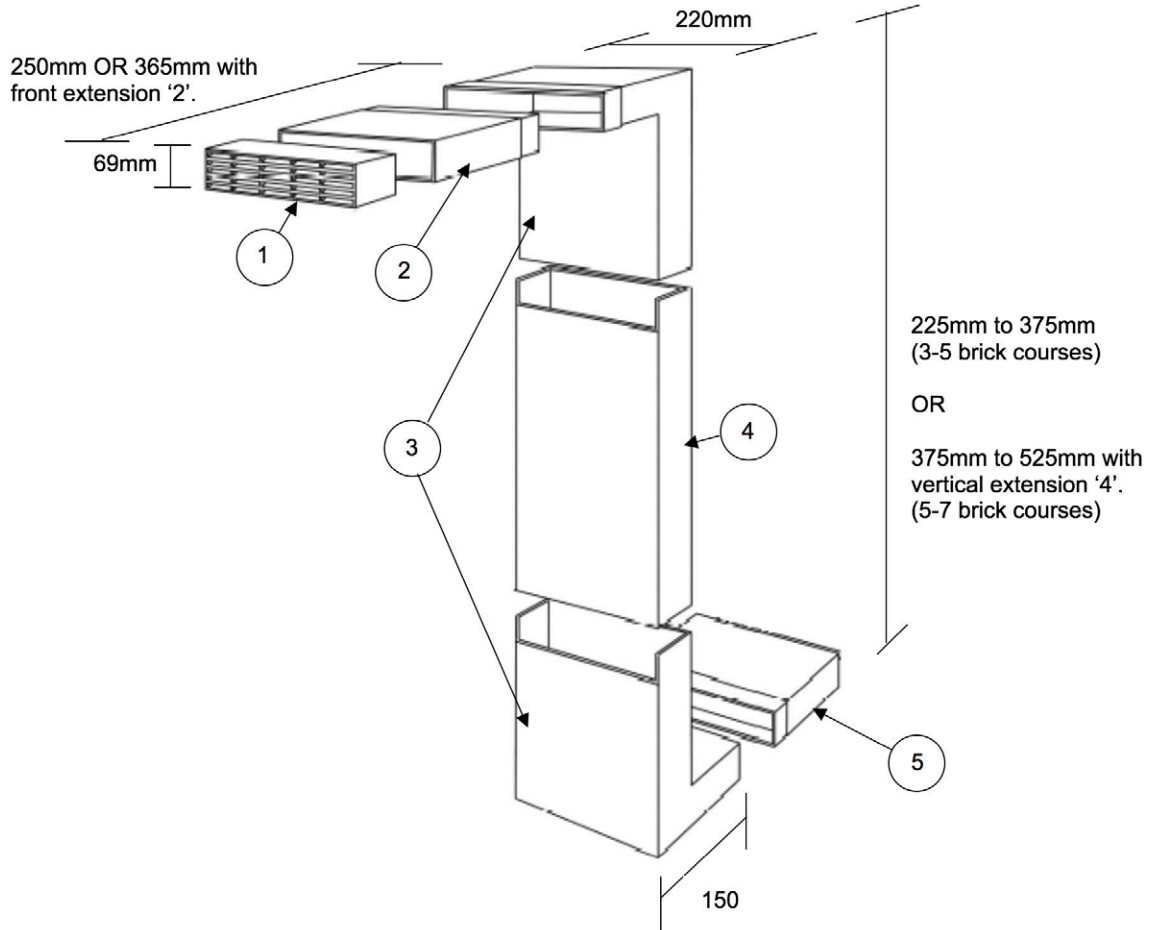

1. Air brick – available in Grey, Buff, Terracotta, Blue/Black, Brown or White.
2. Optional horizontal front extension (provides an additional 115mm)
3. Void ventilator (upper and lower halves – 3-5 course rise)
4. Vertical extension piece (provides an additional 2 brick courses to give 5-7 course rise)
5. Horizontal rear extension (provides an additional 100mm).

OUR PEOPLE. OUR PASSION. OUR PRODUCTS

The components you need for a more successful project.

Bison Precast - Tetron Point - William Nadin Way - Swadlincote - Derbyshire - DE11 0BB

01283 817 500 concrete@bison.co.uk bison.co.uk



**BISON PRECAST**

a Forterra brand

# TECHNICAL GUIDANCE NOTE

Void Ventilators and Air Bricks - 1 December 2015

Typical Vent detail – New Jetfloor edge detail

VENT & AIR BRICK  
SUITABLE FOR 5-7 COURSES  
CAN BE SUPPLIED BY  
FORTERRA

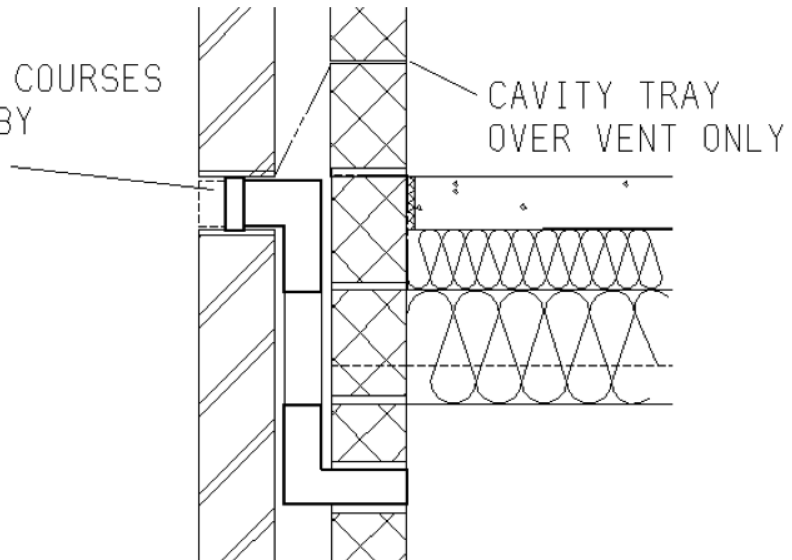

Typical Vent detail – New Jetfloor beam end detail

VENT & AIR BRICK  
SUITABLE FOR 5-7 COURSES  
CAN BE SUPPLIED BY  
FORTERRA

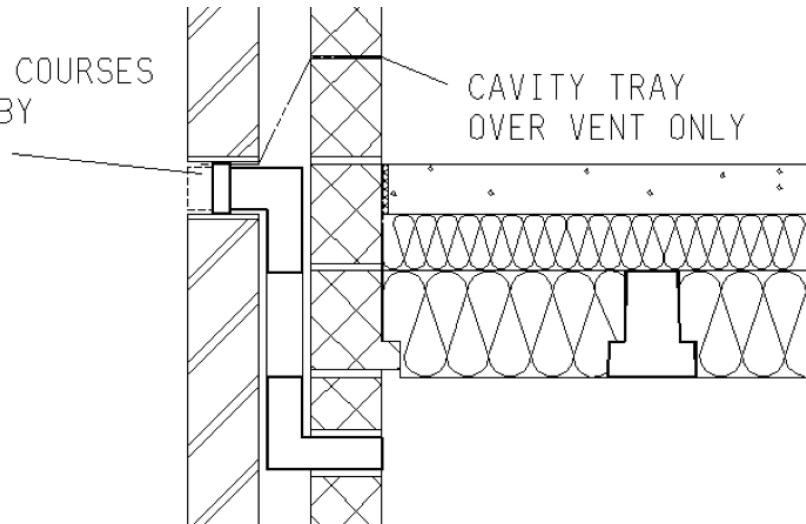

OUR PEOPLE. OUR PASSION. OUR PRODUCTS

The components you need for a more successful project.

Bison Precast - Tetron Point - William Nadin Way - Swadlincote - Derbyshire - DE11 0BB

01283 817 500 concrete@bison.co.uk bison.co.uk